

Fall 1990

## The Revolution in Preliminary Injunctions against Patent Infringement, 24 J. Marshall L. Rev. 225 (1990)

Thomas L. Creel

Donna M. Praiss

Follow this and additional works at: <https://repository.law.uic.edu/lawreview>



Part of the [Civil Law Commons](#), [Civil Procedure Commons](#), [Intellectual Property Law Commons](#), and the [Litigation Commons](#)

---

### Recommended Citation

Thomas L. Creel & Donna M. Praiss, The Revolution in Preliminary Injunctions against Patent Infringement, 24 J. Marshall L. Rev. 225 (1990)

<https://repository.law.uic.edu/lawreview/vol24/iss1/2>

This Article is brought to you for free and open access by UIC Law Open Access Repository. It has been accepted for inclusion in UIC Law Review by an authorized administrator of UIC Law Open Access Repository. For more information, please contact [repository@jmls.edu](mailto:repository@jmls.edu).

# THE REVOLUTION IN PRELIMINARY INJUNCTIONS AGAINST PATENT INFRINGEMENT\*

THOMAS L. CREEL\*\*  
& DONNA M. PRAISS\*\*\*

## INTRODUCTION

Prior to the establishment of the United States Court of Appeals for the Federal Circuit, the preliminary injunction was a frequently-used tool in the hand of the trademark and copyright litigator, but was seldom sought in patent litigations.<sup>1</sup> The regional courts generally required the patent owner to establish validity "beyond question."<sup>2</sup> As a practical matter this meant that unless the patent had gone through a second proceeding after issuance<sup>3</sup> to "strengthen" its statutory presumption of validity<sup>4</sup> no preliminary relief was possible.<sup>5</sup> Furthermore, even for a valid "beyond question" patent, if the defendant could respond in damages, relief was usually denied because the patentee would not be irreparably harmed.<sup>6</sup>

Additionally, if the patent owner did not seek preliminary relief soon after learning of a possible infringement, it was not entitled to relief because the delay was thought to negate irreparable harm.<sup>7</sup>

---

© Copyright 1991 Kenyon & Kenyon.

\* The authors acknowledge the contributions of George E. Badenoch, Charles R. Brainard, Robert T. Tobin, Sheila A. Ozalis, and Christopher C. Roche to this study of preliminary injunctions in the Federal Circuit era.

\*\* Kenyon & Kenyon, New York, New York. Lecturer in Law, Columbia University Law School. B.S. University of Kansas, 1960; LL.B. University of Michigan, 1963.

\*\*\* Kenyon & Kenyon, New York, New York. B.Ch.E. University of Delaware, 1986; J.D. Boston University School of Law, 1989.

1. Foster, *The Preliminary Injunction — A "New" and Potent Weapon in Patent Litigation*, 68 J. PAT. OFF. SOC'Y 281 (1986).

2. See *Smith Int'l, Inc. v. Hughes Tool Co.*, 718 F.2d 1573, 1578 (Fed. Cir.), cert. denied, 464 U.S. 996 (1983).

3. A successful trial against another, a successful reexamination, or a previously-granted preliminary injunction are examples of such secondary proceedings.

4. 35 U.S.C. § 282 (1982).

5. *Smith Int'l, Inc.*, 718 F.2d at 1578.

6. *Id.*

7. See *Uniroyal, Inc. v. Daly-Herring Co.*, 294 F. Supp. 754, 760 (E.D.N.C. 1968)(motion for preliminary injunction denied because patent holder could not

Soon after the establishment of the Court of Appeals for the Federal Circuit, however, cases such as *Smith International, Inc. v. Hughes Tool Co.*<sup>8</sup> heralded a revolution in the enforcement of patent rights. These cases eradicated the formidable barriers that effectively prevented patent holders from preliminarily halting infringing activities.<sup>9</sup>

The revolution occurred largely without a shot being fired. The Federal Circuit merely changed the ground rules such that preliminary injunctions in patent cases are now attainable on the same basis as other litigations. The patentee need only have a "reasonable" likelihood that it can carry its burden of proving infringement by a preponderance of the evidence and that the infringer cannot carry its burden of showing invalidity by clear and convincing evidence.<sup>10</sup> Indeed, if a strong enough showing is made on the validity and infringement issues, irreparable harm is presumed.<sup>11</sup> In any event, irreparable harm has been redefined to mean that a patentee cannot be required to grant a continuing compulsory license, even if the infringer can respond in damages and even if the infringer may be largely put out of business.<sup>12</sup> The Federal Circuit has said that an infringer should be stopped "cold turkey" if all the requirements for a preliminary injunction have been met.<sup>13</sup>

In the wake of the revolution, preliminary injunctions are sought more often against patent infringers.<sup>14</sup> This paper documents the recent status and perceived advantages and disadvantages of seeking patent preliminary injunctions after the revolution. It also provides statistics setting forth the frequency with which preliminary injunctions are now sought and granted and the

---

demonstrate that it would be irreparably harmed due to two and one-half month delay in seeking preliminary relief since patent holder could have presented its claim for patent infringement by way of counterclaim in the accused infringer's action for declaratory judgment of patent invalidity and noninfringement).

8. 718 F.2d 1573 (Fed. Cir. 1983), *cert. denied*, 464 U.S. 996 (1988) (denial of patent holder's motion for preliminary injunction was reversed by the Federal Circuit).

9. See, e.g., Draft, *Patent Preliminary Injunctions and the United States Court of Appeals for the Federal Circuit*, 65 J. PAT. OFF. SOC'Y 131, 132 n.6 (1983); *Smith Int'l, Inc.*, 718 F.2d at 1578 ("courts have over the years developed a reluctance to resort to preliminary injunctions in patent infringement cases").

10. *H.H. Robertson, Co. v. United Steel Deck Inc.*, 820 F.2d 384, 387 (Fed. Cir. 1987).

11. See *Smith Int'l, Inc.*, 718 F.2d at 1581; *Atlas Powder Co. v. Ireco Chem.*, 773 F.2d 1230 (Fed. Cir. 1985).

12. *Atlas Powder Co.*, 773 F.2d at 1233.

13. 773 F.2d at 1232.

14. In 60% of the preliminary injunction cases involving patents that came before the districts courts or were appealed to the Court of Appeals for the Federal Circuit between October 1983 through October 1990, the movant was entitled to a preliminary injunction following the decision. This statistic is based on reported and unreported opinions available on WESTLAW.

grounds upon which preliminary injunctions are most often won or lost.

The practitioner should be aware of the current law in advising a client on the likelihood of success in succeeding in or defending against a preliminary injunction motion. In today's judicial climate, a motion for a preliminary injunction may very well be the only way to get any resolution of a patent infringement suit at all because of the tremendous backlog of civil cases in some jurisdictions.<sup>15</sup>

#### THE JUDICIAL BATTLEGROUND PRIOR TO THE REVOLUTION

In patent infringement cases, where permanent injunctions are usually requested, patent holders also typically ask for preliminary relief in their complaint to restrain alleged infringing activity during the period preceding a final judgment. Such preliminary relief is sought at a stage in the litigation when there is insufficient time to prepare for or to conduct a full hearing on the permanent injunction.<sup>16</sup> Nevertheless, issuance of a preliminary injunction can have a determinative effect on the outcome of the litigation as well as the ability of the parties to pursue the litigation to a final judgment.<sup>17</sup>

For the above reasons, the predecessor courts to the Federal Circuit used caution in deciding whether to grant a preliminary injunction by comparing the likelihood, and the burden, of (1) erroneously granting a preliminary injunction with (2) erroneously denying it.<sup>18</sup> A number of circuit courts relied on four factors in making this comparison.

These four factors 'must be examined in ascertaining the propriety of a preliminary injunction: . . . the moving party must generally show (1) a reasonable probability of eventual success in the litigation and (2) that the movant will be irreparably injured *pendent lite* if relief is not granted. . . . Moreover, while the burden rests upon the moving party to make these two requisite showings, the district court should take

---

15. The immediate past president of the American Bar Association, Robert D. Raven, recently predicted that the civil jury calendar in certain districts will all but preclude civil trials in the near future. See Note, *Attorneys Describe ADR Use in Antitrust and Patent Controversies*, 3 A.D.R. REPORT 403 (1989).

16. Foster, *The Preliminary Injunction — A "New" and Potent Weapon in Patent Litigation*, 68 J. PAT. OFF. SOC'Y 281 (1986).

17. Enjoining an alleged infringer from marketing and selling the accused invention may cripple or possibly destroy the competing business. Consequently, the accused infringer may find the financial burden of a patent infringement suit overwhelming if revenues from sales of the accused invention cannot be used to support the suit. In addition, the time for negotiating an acceptable license with the patent holder may have passed. Metcalf, *Preliminary Injunctions and Their Availability: How to Defend Against the Early Injunction*, 15 A.I.P.L.A. Q. J. 104, 105-06 (1987).

18. *General Leaseways, Inc. v. National Truck Leasing Ass'n*, 744 F.2d 588, 590-91 (7th Cir. 1984).

into account, when they are relevant, (3) the possibility of harm to other interested persons from the grant or denial of the injunction, and (4) the public interest.<sup>19</sup>

One example of a pre-revolutionary preliminary injunction case is *Carter-Wallace, Inc. v. Davis-Edwards Pharmacal Corp.*<sup>20</sup> The patent was for a chemical compound called 2-methyl-2-propyl-1,3 propanediol diacarbamate. In *Carter-Wallace*, the defendant admitted infringement. Indeed, the infringing product was being sold on the strength of its being exactly the same as the patented product since the infringing product was a generic drug. The patent also had every appearance of validity: it was both conspicuously successful and conspicuously profitable; the profits reaped by the patentee and one licensee were so enormous that the United States Department of Justice brought suit to break up the monopoly enjoyed by the two friendly producers; there was industry acquiescence to the patent sixteen out of seventeen years of the patent's life; the industry showed enormous respect for the patent by allowing the patentee to receive a 500% royalty on the manufacturing sales price; and the Second Circuit had upheld a finding of validity on the patent just one year earlier.<sup>21</sup>

There was also strong evidence that the patentee would be irreparably harmed in the absence of a preliminary injunction. The infringer was insolvent and involved in a Chapter 11 bankruptcy proceeding.<sup>22</sup> The defendant was also selling the product at less than one half of the patentee's price.<sup>23</sup> The defendant offered to set aside 5% of its infringing sales into escrow to mitigate damages amounting to about \$.50 per pound compared to the \$20.00 per pound paid by Carter-Wallace's customers.<sup>24</sup> The district court had concluded that "there isn't really any way that [the infringer] . . . is

---

19. *Eli Lilly & Co. v. Premo Pharmaceutical Laboratories, Inc.*, 630 F.2d 120, 136 (3d Cir.1990), *cert. denied*, 449 U.S. 1015 (1980)(patent infringement suit quoting *Constructors Ass'n of Western Pa. v. Kreps*, 573 F.2d 811, 814-15 (3d Cir. 1978)(citations and footnotes omitted)); *See Massachusetts Ass'n for Retarded Citizens, Inc. v. King*, 668 F.2d 602, 607 (1st Cir. 1981); *SK&F, Co. v. Premo Pharmaceutical Laboratories, Inc.*, 625 F.2d 1055, 1066 (3d Cir. 1980)(patent infringement suit); *Telvest, Inc. v. Bradshaw*, 618 F.2d 1029, 1032 (4th Cir. 1980); *Mayview Corp. v. Rodstein*, 480 F.2d 714, 717 (9th Cir. 1973)(patent infringement suit); *Allison v. Froehlke*, 470 F.2d 1123, 1126 (5th Cir. 1972). A number of circuits phrased the first factor as "sufficiently serious questions going to the merits to make them a fair ground for litigation and a balance of hardships tipping decidedly in [movant's] favor." *See Coca-Cola Co. v. Tropicana Prods., Inc.*, 690 F.2d 312, 314-15 (2d Cir. 1982)(trademark case); *Frisch's Restaurants, Inc. v. Elby's Big Boy, Inc.*, 670 F.2d 642, 651 (6th Cir. 1982)(trademark case).

20. 443 F.2d 867 (2d Cir. 1971), *cert. denied*, 412 U.S. 929 (1973)(motion for preliminary injunction denied).

21. *Carter-Wallace*, 169 U.S.P.Q. (BNA) at 646.

22. *Carter-Wallace*, 443 F.2d at 869 (E.D.N.Y. 1971).

23. 443 F.2d at 884.

24. *Id.*

in any position to repair the damage it will have done" if the patent is valid.<sup>25</sup>

The patentee's drug product was not shown to have a price so prohibitive that members of the public were foreclosed from using the drug, despite the public's interest in lower cost generic drugs.

From the evidence submitted, District Judge Dooling concluded, "I do not think [it] is remotely right is [sic] for me to take a patent which the Court has validated and in effect decline to enforce it."<sup>26</sup> Yet, the Second Circuit vacated the preliminary injunction because the patentee did not establish that the patent was valid beyond question. Under the Patent Office's tests for obviousness and misconduct, doubts remained as to the validity of the patent.<sup>27</sup>

### *The "Beyond Question" Standard*

To show probable success, the regional courts required patent holders to establish validity and infringement "beyond question."<sup>28</sup> This stringent "beyond question" standard was only required in patent cases, largely due to the perception of most courts that because of the *ex parte* nature of patent examination, there was no guarantee of validity.<sup>29</sup>

Many courts considered the statutory presumption of patent validity under 35 U.S.C. section 282 insufficient to establish a likelihood of success on the merits.<sup>30</sup> These cases practically required a prior adjudication of the patent or a long period of acquiescence in the industry to show reasonable success on the issues of validity and infringement.<sup>31</sup>

25. *Carter-Wallace*, 169 U.S.P.Q. at 667.

26. 169 U.S.P.Q. at 668.

27. *Carter-Wallace*, 443 F.2d at 880-81.

28. *Mayview Corp. v. Rodstein*, 480 F.2d 714, 717 (9th Cir. 1973); *Bose Corp. v. Linear Design Laboratories*, 467 F.2d 304 (2d Cir. 1972); *Eli Lilly & Co. v. Generix Drug Sales*, 460 F.2d 1096 (5th Cir. 1972); *Carter-Wallace, Inc. v. Davis-Edwards Pharmacal Corp.*, 443 F.2d 867 (2d Cir. 1971), *cert. denied*, 412 U.S. 929 (1973).

29. The Federal Circuit ascribed the circuit courts' hostility towards preliminary relief in patent cases to a "distrust of and unfamiliarity with patent issues and a belief that the *ex parte* examination by the Patent and Trademark Office is inherently unreliable." *Smith Int'l, Inc. v. Hughes Tool Co.*, 718 F.2d 1573, 1578 (Fed. Cir. 1983).

30. See *Mayview Corp. v. Rodstein*, 480 F.2d 714, 718 (9th Cir. 1973) ("The presumption of validity is too slim a reed to support a preliminary injunction in a patent case.")

31. In *Mayview Corp.*, 480 F.2d at 716-17 (9th Cir. 1973), the court stated:

The general rule in equity is that a preliminary injunction will not issue absent a showing of irreparable injury and probable success on the merits. In patent cases a preliminary injunction requires the movant not only

In *Simson Bros. v. Blancard & Co.*,<sup>32</sup> Judge Learned Hand stated, "We have often said that an injunction *pendente lite* in a patent suit should not go except when the patent is beyond question valid and infringed." This doctrine existed as far back as 1888, when the Second Circuit referred to "the wholesome and well-settled rule which requires an adjudication in court, or public acquiescence, as a necessary prerequisite to granting the relief (a preliminary injunction in an action for patent infringement)."<sup>33</sup>

Judge Hand explained the rationale for the substantially heavier burden in patent cases in *Rosenberg v. Groov-Pin Corp.*<sup>34</sup> stating:

The doctrine that in the absence of long acquiescence or adjudication an injunction (i.e., a preliminary injunction in a suit for patent infringement) will not go, is at first blush anomalous in the light of the presumption of validity which courts generally grant to a patent once issued. \* \* \* The other theory is \* \* \* practical. Examiners have neither the time nor the assistance to exhaust the prior art; nothing is more common in a suit for infringement than to find that all the important references are turned up for the first time by the industry of a defendant whose interest animates his search. It is a reasonable caution not to tie the hands of a whole art until there is at least the added assurance which comes from such an incentive.<sup>35</sup>

### *Lack of Irreparable Harm*

Judicial hostility towards preliminary injunctive relief in patent cases was also evidenced by the courts' preemptory correlation of an ability to compensate with monetary damages with a lack of irreparable harm. As long as the accused infringer was solvent and presumably able to compensate the patent holder with monetary damages, the courts denied preliminary relief on the basis of a lack

---

to establish irreparable injury, but also to make a special showing of the likelihood that he will prevail on the merits.

This special burden is said to require proof that the validity of the patent has been established beyond question, either by prior adjudication or public acquiescence.

Similarly, in *Bose Corp. v. Linear Design Labs., Inc.*, 340 F. Supp. 513, 516 (S.D.N.Y. 1971), *modified*, 467 F.2d 304 (2d Cir. 1972), the court held that absent "prior adjudication of validity, or long public acquiescence of validity beyond question, the granting of a preliminary injunction in a patent infringement suit is improper, notwithstanding the statutory presumption of validity." *But see* *Eli Lilly & Co. v. Premo Pharmaceutical Labs*, 630 F.2d 120, 207 U.S.P.Q. (BNA) 769, (3d Cir.), *cert. denied*, 449 U.S. 1014, 208 U.S.P.Q. 88 (BNA) (1980); *Tyrolean Handbag v. Empress Handbag*, 122 F. Supp. 299, 302, 102 U.S.P.Q. (BNA) 382, 384 (S.D.N.Y. 1954).

32. 22 F.2d 498, 499 (2d Cir. 1927).

33. *Dickerson v. De La Vergne Refrigerating Mach. Co.*, 35 F. 143, 147-48 (C.C.S.D.N.Y. 1888).

34. 81 F.2d 46 (2d Cir. 1936).

35. 81 F.2d at 47.

of an immediate, irreparable harm.<sup>36</sup>

The patentee's delay in seeking a preliminary injunction was also considered sufficient evidence of a lack of immediate and irreparable harm.<sup>37</sup>

#### *Balance of Hardships & Public Interest*

Although the courts often recited the balance of hardships and the public interest as factors to be considered, they were seldom considered in patent cases. In the absence of a preliminary injunction, alleged infringers continued their activities despite the disproportionate amount of time, money and effort invested in the accused invention. Judicial consideration of the socio-economic aspects of the situation, which would have probably revealed a chilling effect on research and development budgets was noticeably missing from these pre-revolutionary decisions.

#### THE STATUS OF THE REVOLUTION TODAY

As noted above, it was generally believed that preliminary injunctions were rarely granted in patent cases before the Federal Circuit was established.<sup>38</sup> Surprisingly, a 1978 survey indicated that about 41% of preliminary injunction motions in patent litigation were granted despite the judicially-created obstacles.<sup>39</sup> This early survey, however, spanned a twenty-five year period between January 1953 and September 1978. It incorporated only forty-seven cases reported in the United States Patent Quarterly, or less than an average of two decisions per year.<sup>40</sup> The present survey includes eighty-six patent preliminary injunction cases available on a commercial legal database for only a seven year period from the *Smith International, Inc. v. Hughes Tool Co.*<sup>41</sup> decision in October 1983

---

36. *Nuclear-Chicago Corp. v. Nuclear Data, Inc.*, 465 F.2d 428, 430, 174 U.S.P.Q. (BNA) 381 (7th Cir. 1972); *Rohm & Haas Co. v. Mobil Oil Corp.*, 525 F. Supp. 1298, 1307 (D. Del. 1981); *Jenn-Air Corp. v. Modern Maid Co.*, 499 F. Supp. 320, 333 (D. Del.), *aff'd*, 659 F.2d 1068 (3d Cir. 1981).

37. See *Uniroyal, Inc. v. Daly-Herring Co.*, 294 F. Supp. 754, 760 (E.D.N.C. 1968) (motion for preliminary injunction denied because patent holder could not demonstrate that it would be irreparably harmed due to two and one-half month delay in seeking preliminary relief since patent holder could have presented its claim for patent infringement by way of counterclaim in the accused infringer's action for declaratory judgment of patent invalidity and noninfringement).

38. Metcalf, *Preliminary Injunctions and Their Availability: How to Defend Against the Early Injunction*, 15 A.I.P.L.A. Q. J. 104, 107-108 (1987).

39. Dorr & Duft, *Patent Preliminary Injunctive Relief*, 60 J. PAT. OFF. SOC'Y 597, 599 (1978).

40. *Id.*

41. 718 F.2d 1573, 219 U.S.P.Q. (BNA) 686 (Fed. Cir. 1983), *cert. denied*, 464 U.S. 996, 220 U.S.P.Q. (BNA) 385 (1983) (motion for preliminary injunction denied and reversed on appeal).



through October 1990 — a quickening pace of more than ten decisions per year on average.<sup>42</sup>

We use the *Smith International, Inc.*, decision as a milestone because it was in this decision that the Federal Circuit first assigned to patent cases the same standard used in copyright cases.<sup>43</sup> The circuit court stated that “where validity and continuing infringement have been clearly established, as in this case, immediate irreparable harm is presumed,” adding, “This is the rule in copyright cases.”<sup>44</sup>

Although patent litigation is not easily generalized and statistically analyzed given the factual distinctions of each case, this method is commonly used to assess judicial developments. This paper dutifully follows suit.

The incidents of preliminary injunctions that were granted, denied or vacated in the federal courts are tabulated in the appendices<sup>45</sup> and analyzed in Tables 1-3.<sup>46</sup> The frequency of reasons given for not granting preliminary injunctions in patent cases is listed in Table 4.

Referring to Table 1, 56%<sup>47</sup> of the cases leaving the Federal Circuit entitled the patent holder to a preliminary injunction for the period October 1983 through October 1990. For the same period, this figure was 62%<sup>48</sup> in the district courts and 60%<sup>49</sup> overall.<sup>50</sup>

---

42. See Appendix 1 for a list of the preliminary injunction cases involving patents that were included in this survey.

43. See *Roper Corp. v. Litton Sys., Inc.*, 757 F.2d 1266, 1271, 225 U.S.P.Q. (BNA) 345, 348-48 (Fed. Cir. 1985).

44. *Smith Int'l, Inc.*, 718 F.2d at 1581, 219 U.S.P.Q. (BNA) at 692 (footnote omitted).

45. Appendices 2 and 3 are tabulations of all preliminary injunction motions in patent cases before the Federal Circuit and federal district courts respectively. Appendix 4 superposes the data of both appendices 2 and 3.

46. Table 1 reports the incidence of preliminary injunctions granted over various time intervals during the course of the survey. Table 2 reports the percentage of preliminary injunctions granted in the Federal Circuit compared to the percentage of patents found not invalid by the Federal Circuit. The number of preliminary injunctions that were granted on patents that were not previously adjudicated is reported in Table 3.

47. This figure represents 14 motions granted out of 25 motions decided.

48. This figure represents 34 motions granted out of 55 motions decided.

49. This figure represents 48 motions granted out of 80 motions decided.

50. These statistics were computed as the percentage of preliminary injunction motions granted over the total number of preliminary injunction motions decided, exclusive of vacated or modified decisions.

*Table 1. Percentage of Preliminary Injunctions Granted\* From Smith International, Inc. v. Hughes Tool Co. Through October, 1990*

|  |     |
|--|-----|
| In the Federal Circuit                                 | 56% |
| In the Federal District Courts                         | 62% |
| In the Federal Circuit and the Federal District Courts | 60% |

\* This statistic represents the number of preliminary injunction motions granted out of the total number of preliminary injunction motions granted or denied. Cases where the Federal Circuit vacated the lower court decision are not included.

It would be interesting to compare these preliminary injunction statistics, which extend through October, 1990, with statistics for litigation after trial. Unfortunately, the only "trial" statistics available are through 1989. These statistics show that 61% of the patents brought before the Federal Circuit between 1980 and 1989 were found valid after trial.<sup>51</sup> The figure for winning patentees is expected to be lower than 61% since this figure only represents the determination of validity; it does not include infringement or enforceability determinations. The success rate in obtaining a patent preliminary injunction over that same period was 71% as shown in table 2. Therefore, through 1989 the success rate in obtaining a patent preliminary injunction, at least at the Federal Circuit level, is higher than the success rate after a trial on the merits.

*Table 2. Preliminary Injunctions Granted vs. Patents Found Not Invalid by the Federal Circuit Through the Year 1989*

|  |     |
|--|-----|
| Preliminary injunctions granted                              | 71% |
| Patents found not invalid by the Federal Circuit after trial | 61% |

As shown in Table 3, at least 72%<sup>52</sup> of the preliminary injunction cases before the Federal Circuit involved a patent that was not previously adjudicated. In the federal district courts, 84%<sup>53</sup> of the cases involved unadjudicated patents. Overall, 80%<sup>54</sup> of the patent preliminary injunction motions before the federal courts involved unadjudicated patents. Of those cases involving unadjudicated pat-

---

51. R. HARMON, PATENTS AND THE FEDERAL CIRCUIT: 1987-1989 CUMULATIVE SUPPLEMENT 275-79 (1990). This figure is based on 125 patents where the Federal Circuit either affirmed a finding of no invalidity or reversed a finding of invalidity out of a total of 204 patents where findings of validity or invalidity were either affirmed or reversed.

52. This figure represents 18 motions involving unadjudicated patents out of 25 motions in total.

53. This figure represents 46 motions involving unadjudicated patents out of 55 motions in total.

54. This figure represents 64 motions involving unadjudicated patents out of 80 motions in total.

**Table 3. Unadjudicated Patents & Preliminary Injunctions\****In the Federal Circuit*

|   |     |
|---|-----|
| Total number of motions involving adjudicated patents   | 7   |
| Total number of motions involving unadjudicated patents   | 18  |
| Total number of motions   | 25  |
| Percentage of motions involving unadjudicated patents   | 72% |
| Percentage of preliminary injunctions granted among all motions involving unadjudicated patents | 44% |
| Percentage of preliminary injunctions granted among all motions involving adjudicated patents   | 86% |

*In the Federal District Courts\*\**

|   |     |
|---|-----|
| Total number of motions involving adjudicated patents   | 9   |
| Total number of motions involving unadjudicated patents   | 46  |
| Total number of motions   | 55  |
| Percentage of motions involving unadjudicated patents   | 84% |
| Percentage of preliminary injunctions granted among all motions involving unadjudicated patents | 65% |
| Percentage of preliminary injunctions granted among all motions involving adjudicated patents   | 44% |

*In the Federal Circuit and the Federal District Courts\*\**

|   |     |
|---|-----|
| Total number of motions involving adjudicated patents   | 16  |
| Total number of motions involving unadjudicated patents   | 64  |
| Total number of motions   | 80  |
| Percentage of motions involving unadjudicated patents   | 80% |
| Percentage of preliminary injunctions granted among all motions involving unadjudicated patents | 59% |
| Percentage of preliminary injunctions granted among all motions involving adjudicated patents   | 63% |

\* Those cases where the Federal Circuit vacated and remanded to the lower courts are not included in these statistics.

\*\* These statistics do not include *Joslyn Mfg. Co. v. Amerace Corp.*, No. 89 C 5775 (N.D. Ill. Mar. 15, 1990) (where the court made no determination on the motion for preliminary injunction but scheduled an early trial). Nor do they include *Con-Vey/Keystone, Inc. v. A.M. Indus., Inc.*, No. 88-1253-DA (D. Or. June 4, 1990) (where a review of a grant of a preliminary injunction resulted in the case being remanded).

ents, roughly 59% of the motions for preliminary injunction were granted. These statistics illustrate the surge of preliminary injunction motions brought in patent infringement suits where there were no previous adjudications of patent validity. The statistics also illustrate the motions often succeed. In addition, the statistics show that the likelihood of succeeding on a preliminary injunction motion no longer depends on a prior adjudication.

The overall rise in the number of preliminary injunction motions granted since the pre-Federal Circuit era is an expected consequence of the redefined standards espoused by the Federal Circuit. It is also not surprising that most of the preliminary injunctions granted involved unadjudicated patents after the demise of the "beyond question" standard and after the apparent surge in the

number of preliminary injunction motions presented to the federal courts.

### *The Present Battlefield Rules*

The criteria used to evaluate a motion for a preliminary injunction have been revised since the creation of the Federal Circuit. These revised criteria "sound" much the same as the previous standards. However, the subtle change in language accompanies an enormous difference in philosophy. The factors are now:

- (1) Whether the plaintiff will have an adequate remedy at law or will be irreparably harmed if the injunction does not issue;
- (2) whether the threatened injury to the plaintiff outweighs the threatened harm the injunction may inflict on the defendant;
- (3) whether the plaintiff has at least a reasonable likelihood of success on the merits; and
- (4) whether the granting of a preliminary injunction will disserve the public interest.<sup>55</sup>

"These factors, taken individually, are not dispositive; rather, the district court must weigh and measure each factor against the form and magnitude of the relief requested."<sup>56</sup> Apparently, this means that if a patentee does not have a strong case on validity and infringement, but has a very strong case on irreparable harm, it is entitled to an injunction. Conversely, relief should be granted where there is a strong case supporting validity and infringement, but a less persuasive case for irreparable harm.

Although no one factor is to be given more weight, courts have denied preliminary injunction motions based on just one factor.<sup>57</sup>

---

55. *Roper Corp. v. Litton Sys., Inc.*, 757 F.2d 1266, 1269 (Fed. Cir. 1985).

56. *Hybritech, Inc. v. Abbott Labs.*, 849 F.2d 1446, 1451 (Fed. Cir. 1988)(citing *Roper Corp. v. Litton Sys., Inc.*, 757 F.2d 1266, 1269 n.2 (Fed. Cir. 1985)).

57. *Gerber Garment Technology, Inc. v. Lectra Sys., Inc.*, 916 F.2d 683, 16 U.S.P.Q. 2d (BNA) 1436 (Fed. Cir. 1990) (After finding no error in the grant of summary judgment of invalidity, the Federal Circuit stated that the plaintiff "necessarily cannot possibly establish a basis for a preliminary injunction."); *Oscar Mayer Foods Corp. v. Sara Lee Corp.*, 743 F. Supp. 1326 (W.D. Wis. 1990) (balance of hardships favored defendant because plaintiff did not make as clear a showing that it was likely to succeed on the merits as it did in a previous motion against defendant's other product and the trial was expediated); *Astro-Med, Inc. v. Western Graphtec, Inc.*, No. 88-3348 (C.D. Cal. Oct. 20, 1988), *aff'd*, 878 F.2d 1447 (Fed. Cir. 1989) (failure to show likelihood of success on infringement claim); *Russell William, Ltd. v. ABC Display & Supply, Inc.*, 11 U.S.P.Q.2d (BNA) 1812 (E.D.N.Y. 1989) (lack of irreparable harm due to two year delay in seeking preliminary relief); *MacDonald Assoc. v. Crownmark Corp.*, 2 U.S.P.Q.2d (BNA) 1235 (D.R.I. 1987) (even probability of success on issue of validity); *Tennant Co. v. Hako Minuteman, Inc.*, 1 U.S.P.Q.2d (BNA) 2042 (N.D. Ill. 1986) (lack of irreparable harm in light of defendant's proof of financial stability and plaintiff's delay of less than one year); *SMI Indus. Canada, Ltd. v. Caelter Indus., Inc.*, 586 F. Supp. 808 (N.D.N.Y. 1984) (failure to show validity under the "beyond question" standard).

Table 4 indicates that the most frequently cited reason for denying a preliminary injunction motion is no longer "no reasonable likelihood of success because the patent was not shown to be valid."<sup>58</sup> Rather lack of irreparable harm is the factor now more frequently relied upon in denying a preliminary injunction.

*Table 4. Reasons for Not Granting a Preliminary Injunction in Patent Cases Since Smith International, Inc. v. Hughes Tool Co.\**

| REASONS**  | NUMBER OF OCCURRENCES |
|--|-----------------------|
| A. No showing of irreparable harm                | 25                    |
| 1. Movant's delay in filing suit was a factor    | 12                    |
| B. No reasonable likelihood of success           | 19                    |
| 1. The patent was not clearly valid              | 12                    |
| 2. No infringement was shown                     | 11                    |
| 3. Unenforceability or misuse found              | 1                     |
| C. Balance of hardships weighed against patentee | 16                    |
| D. Public interest did not favor patentee        | 11                    |

\* These statistics were derived from a total of 37 cases through October 1990. The total here includes all cases where a preliminary injunction was denied, or where an injunction was granted by a lower court and vacated by the Federal Circuit, or where the district court set an early trial in lieu of a determination on the preliminary injunction motion, or where the grant of a preliminary injunction was remanded by a lower court.

\*\* This table reflects the fact that preliminary injunctions were often not granted for a number of reasons. It therefore contains some overlap and the total number of reasons does not equal the total number of cases where preliminary injunctions were not granted.

Turning from cold, empty numbers, this paper now focuses on the elements of contemporary motions for preliminary injunctions as exemplified in some significant patent cases.

#### *Reasonable Likelihood of Success*

The Federal Circuit removed the onerous "beyond question" burden of proof in *Atlas Powder Co. v. Ireco Chemicals*.<sup>59</sup> The double standard for patent cases was erased with the statement that "[t]he burden upon the movant should be no different in a patent case than for other kinds of intellectual property, where, generally,

58. The most often cited reason for denying a motion for preliminary injunction was "no showing of irreparable harm." Between October 1983 and October 1990, there were twenty-five occurrences. There were nineteen occurrences where "no likelihood of success" was the reason for the denial. See Table 4; compare Dorr & Duft, *Patent Preliminary Injunctive Relief*, 60 J. PAT. OFF. SOC'Y 597, 635 (1978) (where seventeen denials were related to an insufficient showing of validity and fifteen denials were related to a lack of irreparable harm).

59. 773 F.2d 1230, 1233 (Fed. Cir. 1985).

only a 'clear showing' is required."<sup>60</sup> The court chose to respond to this issue even though the patent in *Atlas Powder* was previously adjudicated valid and infringed in an action against another defendant.<sup>61</sup> As a result of lowering the burden of proof, a reasonable likelihood of success on the merits has been found in many situations where the patent was not previously adjudicated.<sup>62</sup> Indeed, as

---

60. *Id.*

61. See *Roper Corp. v. Litton Sys., Inc.*, 757 F.2d 1266 (Fed. Cir. 1985) (Roper Corp. obtained a favorable adjudication of the validity of its patent in a previous litigation against Raytheon Co., however, the Federal Circuit affirmed the district court's denial of Roper Corp.'s preliminary injunction motion due to a lack of irreparable harm by the patent assignee.); *Smith Int'l, Inc. v. Hughes Tool Co.*, 664 F.2d 1373 (9th Cir.), *cert. denied*, 456 U.S. 976 (1983) (the Federal Circuit reasoned that the patents were established to be valid and infringed under the "beyond question" standard since the patents were previously adjudicated valid and an admission of infringement was equivalent to an adjudication on that issue).

62. See *Illinois Tool Works, Inc. v. Grip-Pak, Inc.*, 906 F.2d 679 (Fed. Cir. 1990); *Rosemont, Inc. v. United States Int'l Trade Comm'n*, 15 U.S.P.Q. 2d (BNA) 1569 (Fed. Cir. 1990); *Bristol-Myers Co. v. United States Int'l Trade Comm'n*, No. 89-1530 (Fed. Cir. Dec. 8, 1990); *E.I. duPont de Nemours & Co. v. Polaroid Graphics Imaging, Inc.*, 887 F.2d 1095 (Fed. Cir. 1989); *Southwest Aerospace Corp. v. Teledyne Indus., Inc.*, 884 F.2d 1398 (Fed. Cir. 1989); *P.W. Woo & Sons, Inc. v. Antelope Entr. Co., Ltd.*, 871 F.2d 1096 (Fed. Cir. 1989); *Application Art Labs. Co., Ltd. v. Marita*, 13 U.S.P.Q.2d (BNA) 1254 (Fed. Cir. 1989); *Dream-lite Holdings Ltd. v. Kraser*, 818 F. 2d 1446, 12 U.S.P.Q.2d (BNA) 1574 (Fed. Cir. 1989); *American Parking Meter Advertising, Inc. v. Visual Media, Inc.*, 848 F.2d 1244 (Fed. Cir. 1988); *Oscar Mayer Foods Corp. v. Sara Lee Corp.*, 743 F. Supp. 1326, 15 U.S.P.Q.2d (BNA) 1204 (W.D. Wis. 1990); *Pharmacia, Inc. v. Frigritronics, Inc.*, 727 F. Supp. 710 (D. Mass. 1990); *Ortho Pharm. Corp. v. Smith*, 15 U.S.P.Q.2d 1856 (E.D. Pa. 1990); *Saes Getters S.P.A. v. Ergenics, Inc.*, No. 89-649 (D.N.J. July 30, 1990) 15 U.S.P.Q.2d (BNA) 1212 (D.N.J. 1990); *Crucible Materials Corp. v. Sumitomo Metals Co.*, 719 F. Supp. 14 (D.D.C. 1989); *Spalding & Evenflo Co. v. Acushnet Co.*, 718 F. Supp. 1023, 2 U.S.P.Q.2d (BNA) 1070 (D. Mass. 1989); *Moore Business Forms, Inc. v. Wallace Computer Serv., Inc.*, 14 U.S.P.Q.2d (BNA) 1849 (N.D. Ind. 1989); *We Care, Inc. v. Ultra-Mark Int'l Corp.*, 14 U.S.P.Q.2d (BNA) 1804 (D. Minn. 1989); *Amgren, Inc. v. Chugai Pharm. Co. Ltd.*, 13 U.S.P.Q.2d 1737 (D. Mass. 1989); *Automotive Prod. plc. v. Federal-Mogul Corp.*, 11 U.S.P.Q.2d (BNA) 1471 (E.D. Mich. 1989); *Biocraft Labs. v. Bristol-Myers Co.*, No. 89-158 (D.N.J. Feb. 24, 1989); *Zeller Plastik, Koehn, Grabner & Co. v. Joyce Molding Corp.*, 698 F. Supp. 1204 (D.N.J. 1988); *Lubrizol Corp. v. Exxon Corp.*, 696 F. Supp. 302, 7 U.S.P.Q.2d (BNA) 1513 (N.D. Ohio 1988); *American Antenna Corp. v. Wilson Antenna Corp.*, 690 F. Supp. 924 (D. Nev. 1988); *Sensormatic Elec. Corp. v. Minnesota Mining Mfg. Co.*, 10 U.S.P.Q.2d (BNA) 1467 (S.D. Fla. 1988); *Designs for Leisure, Ltd. v. Murrey & Sons Co.*, 9 U.S.P.Q.2d (BNA) 1159 (C.D. Cal. 1988); *Johnson & Johnson Consumer Prod., Inc. v. Ormco Corp.*, Nos. 87-341, 87-547 (D. Del. Sept. 29, 1988); *Tri-Tech, Inc. v. Engineering Dynamics Corp.*, No. 88-0883-H (D. Mass. June 23, 1988); *Toro Co. v. Textron, Inc.*, 703 F. Supp. 417, 5 U.S.P.Q.2d (BNA) 1616 (W.D.N.C. 1987); *Imi-Tech Corp. v. Gagliani*, 691 F. Supp. 214, 6 U.S.P.Q.2d (BNA) 1241 (S.D. Cal. 1987); *Pittway Corp. v. Black & Decker, Inc.*, 667 F. Supp. 585, 5 U.S.P.Q.2d (BNA) 1052 (N.D. Ill. 1987); *John Fluke Mfg. Co. v. North Amer. Soar Corp.*, 5 U.S.P.Q.2d (BNA) 1657 (D.N.J. 1987); *Medeco Security Locks v. Cinquini*, 229 U.S.P.Q. (BNA) 398 (D. Mass. 1987); *Turbo Tek Entr., Inc. v. F.P. Feature Prod., Inc.*, No. 87-C 7438 (N.D. Ill. Oct. 7, 1987); *Rexnord, Inc. v. Laitram Corp.*, 1 U.S.P.Q.2d (BNA) 1923 (E.D. Wis. 1986); *Augat, Inc. v. John Mezzalingua Assoc., Inc.* 642 F. Supp. 506, 1 U.S.P.Q.2d (BNA) 1912

shown in Table 3, a patentee is likely to prevail in 59% of the litigations where the patent has not been previously adjudicated. Under this lower standard, a reasonable likelihood of success has been found where the statistical probability of success was less than fifty percent.<sup>63</sup>

In *Roper Corp. v. Litton Systems, Inc.*,<sup>64</sup> the Federal Circuit established that the statutory presumption of patent validity alone, if not rebutted, is a sufficiently "clear showing" of the likelihood of success on the issue of validity.<sup>65</sup> Therefore, the onus of proving validity no longer lies with the patent holder until that issue is attacked by the accused infringer. Even then, a patentee must only show a "reasonable" likelihood that it will prevail on the validity issue.

Here the redefined burdens of proof by the Federal Circuit come into play as well. Thus, an infringer can only overcome the presumption of validity by clear and convincing evidence. A patentee, on its motion, need only convince the court that there is a reasonable likelihood that the infringer cannot carry this heavy burden of proof. *American Parking Meter Advertising, Inc. v. Visual Media, Inc.*,<sup>66</sup> is an instructive case showing how far the pendulum has swung. There, the invention was simply a small curved metal "billboard" fitted to a parking meter, as shown below. The patent had not been previously litigated, nor apparently was evidence submitted of industry acquiescence. The mere naked presumption of validity was relied upon.

---

(N.D.N.Y. 1986); *Gravity Guidance, Inc. v. Weseman*, 725 F.2d 690, 220 U.S.P.Q. (BNA) 1038 (D. Minn. 1983).

63. In *Hybritech, Inc. v. Abbott Laboratories*, 849 F.2d 1446 (Fed. Cir. 1988), *aff'g* 4 U.S.P.Q.2d 1001 (C.D. Cal. 1987), Hybritech was involved in an interference proceeding as a junior party subsequent to a prior adjudication of patent validity against another defendant. Abbott produced evidence that only 25 percent of the junior parties prevail in an interference proceeding. Despite the fact that the interference proceeding raised the possibility that Hybritech would be denied priority by the time the infringement litigation was resolved, the district court concluded that Hybritech was likely to establish an earlier invention date. The Federal Circuit found that the district court did not abuse its discretion in so holding. *Hybritech, Inc.*, 849 F.2d at 1451-52; *cf. Zenith Laboratories, Inc. v. Eli Lilly & Co.*, 460 F. Supp. 812, 820 n.4 (D.N.J. 1978) (quoting *American Cyanamid Co. v. Ethicon, Ltd.*, [1975] A.C. 396 (H.L.), a seminal opinion on the standard for a preliminary injunction in Great Britain, which is substantially lower than the United States standard: "the purpose in giving the court discretion to grant interlocutory relief is stultified by the requirement that discretion may not be exercised except on a showing that the plaintiff is more than 50% likely to succeed on the merits at trial.").

64. 757 F.2d 1266 (Fed. Cir. 1985), *aff'g* 589 F. Supp. 823 (N.D. Ill. 1984).

65. "A patent is born valid [and] remains valid until a challenger proves it was stillborn or had birth defects. . . ." *Roper Corp. v. Litton Sys., Inc.*, 757 F.2d 1270, 1271 (Fed. Cir. 1985).

66. 693 F. Supp. 1253, 1255 (D. Mass. 1987), *aff'd*, 848 F.2d 1243 (Fed. Cir. 1988).

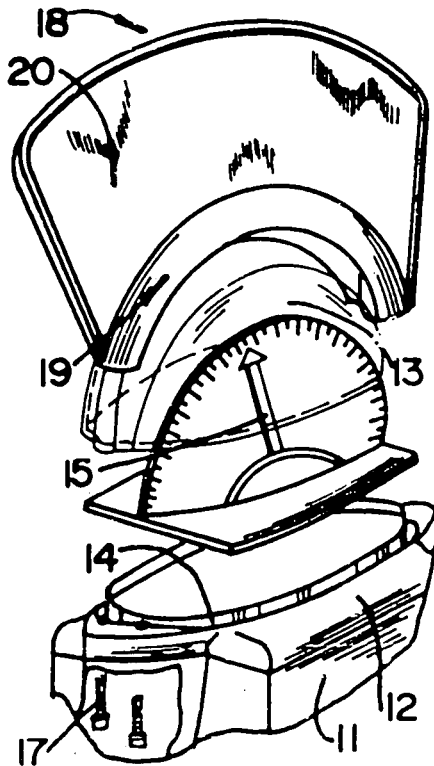

FIGURE 1

The Massachusetts District Court justified its finding that there was a reasonable likelihood of success on the issue of validity with the following language.

The validity of the patent in issue presents a problem which may be difficult to resolve at the time of trial. While we have had an opportunity *only for a cursory glance at the prior art, and less than an adequate opportunity to study the plaintiff's product*, we do not have conclusive evidence of non-obviousness. We are not, however, called upon to make a decision upon validity or lack of validity of the patent at this stage. The question is: is there a reasonable likelihood that the plaintiff will prevail on the issue of validity and the answer for the moment appears to be "yes". Plaintiff for now must persuade us of the existence of the likelihood of prevailing. It is aided in this regard by the presumption of validity which would apply at a trial on the merits. At that trial, the burden of showing invalidity by clear and convincing evidence would have to be carried by the defendants. That presumption, and its effect upon plaintiff's present task, is sufficient to carry the present day for plaintiff on validity. The fact that defendants copied plaintiff's device indicates that there is a reasonable probability of success on the claim of infringement.<sup>67</sup>

67. *American Parking Meter*, 693 F. Supp. at 1254-55 (emphasis added).



The infringement question was also hotly contested.

The Federal Circuit affirmed 2 to 1 the district court's decision without mentioning the validity issue.

The trend seems to be for accused infringers to admit infringement only for the purpose of the preliminary injunction proceeding.<sup>68</sup> An admission of infringement for this limited purpose, however, may be self-defeating because it is considered a "clear showing" of infringement.<sup>69</sup> Combined with a "clear showing" of validity, the admission of infringement will entitle the movant to a presumption of irreparable harm that is not easily rebutted. Thus, an admission of infringement may result in the accused infringer discarding two of the four factors on which a preliminary injunction motion is granted.

### *Irreparable Harm*

Where once the nonmovant merely had to show an ability to compensate the movant with monetary damages for the court to find a lack of irreparable harm, the Federal Circuit now salutes the sanctity of a valid and infringed patent and requires additional evidence to establish that irreparable harm is not an immediate danger.<sup>70</sup>

---

68. See *Chrysler Motors Corp. v. Auto Body Panels of Ohio, Inc.*, 908 F.2d 951 (Fed. Cir. 1990); *Bristol-Myers Co. v. United States Int'l Trade Comm'n*, 892 F.2d 1050 (Fed. Cir. 1989), *rev'g* Inv. No. 337-TA-293 (I.T.C. June 3, 1989); *E.I. duPont de Nemours & Co. v. Polaroid Graphics Imaging, Inc.*, 887 F.2d 1095 (Fed. Cir. 1989), *aff'g* 706 F. Supp. 1135 (D. Del. 1989); *Southwest Aerospace Corp. v. Teledyne Indus., Inc.*, 884 F.2d 1398 (Fed. Cir. 1989), *aff'g* 702 F. Supp. 870 (N.D. Ala. 1988); *Smith Int'l, Inc. v. Hughes Tool Co.*, 718 F.2d 1573 (Fed. Cir. 1983); *cert. denied*, 464 U.S. 966 (1988); *Upjohn Co. v. Medtron Laboratories, Inc.*, No. 87 Cir. 5773 (SWK) (S.D.N.Y. Oct. 12, 1990) (unpublished disposition); *Ortho Pharmaceutical Corp. v. Smith*, 15 U.S.P.Q.2d (BNA) 1856 (E.D. Pa. 1990); *Crucible Materials Corp. v. Sumitomo Metals Co., Ltd.*, 719 F. Supp. 14 (D.D.C. 1989); *Biocraft Laboratories v. Bristol-Myers Co.*, No. 89-158 (D.N.J. Feb. 24, 1989); *Sensormatic Elects. Corp. v. Minnesota Mining & Mfg. Co.*, 10 U.S.P.Q.2d (BNA) 1467 (S.D. Fla. 1988); *Johnson & Johnson Consumer Prod., Inc. v. Ormco Corp.*, Nos. 87-341, 87-547 (D. Del. Sept. 29, 1988); *John Fluke Mfg. Co. v. North Amer. Soar Corp.*, 5 U.S.P.Q.2d (BNA) 1657 (D.N.J. 1987); *Pittway Corp. v. Black & Decker, Inc.*, 667 F. Supp. 585 (N.D. Ill. 1987); *Glasstech, Inc. v. AB Kyro Oy*, 635 F. Supp. 465 (N.D. Ohio 1986).

69. *E.I. duPont de Nemours & Co. v. Polaroid Graphics Imaging, Inc.*, 706 F. Supp. 1135, 1144 (D. Del. 1989), *aff'd*, 887 F.2d 1095 (Fed. Cir. 1989) ("by virtue of [the defendant's] admission that it infringes each of the asserted claims in the . . . patent [the plaintiff] has made a clear showing of infringement. Therefore we will invoke the presumption of irreparable harm"); see *Smith Int'l, Inc. v. Hughes Tool Co.*, 718 F.2d at 1580 (where Smith's "admissions in the district court's pre-trial orders amount[ed] to an adjudication that Smith had infringed the patents").

70. See *Atlas Powder v. Ireco Chem.*, 773 F.2d 1230, 1233 (Fed. Cir. 1985) *distinguished*, 711 F. Supp. 975 (9th Cir.). In *Atlas Powder*, the Federal Circuit found that this compensation argument

The movant may show irreparable harm by one of two methods: (1) by making a "clear showing" of validity and infringement thereby entitling the movant to a "presumption" of irreparable harm<sup>71</sup>, or (2) by establishing irreparable harm with independent facts.

Like other legal presumptions, the presumption of irreparable harm is rebuttable by clear evidence.<sup>72</sup> For example, the nonmovant may raise prior art not considered by the Patent and Trademark Office (PTO) and inequitable conduct of the applicants before the PTO. Lack of public acquiescence, including evidence of other infringing activity, and the fact that the patent-in-suit is newly issued are also factors that may overcome the presumption.

The nonmovant's ability to compensate, however, is no longer conclusive of a lack of irreparable harm; it is merely a factor to be

---

downplay[s] the nature of the statutory right to exclude others from making, using, or selling the patented invention throughout the United States. . . . While monetary relief is often the sole remedy for past infringement, it does not follow that a money award is also the sole remedy against future infringement. The patent statute further provides injunctive relief to preserve the legal interests of the parties *against future infringement* which may have market effects never fully compensable in money. If monetary relief were the sole relief afforded by the patent statute, then injunctions would be unnecessary and infringers could become compulsory licensees for as long as the litigation lasts. *Id.* (emphasis in original, citations omitted).

71. *Smith Int'l, Inc. v. Hughes Tool Co.*, 718 F.2d 1573, 1581 (Fed. Cir. 1983) ("where validity and continuing infringement have been clearly established . . . immediate irreparable harm is presumed.').

72. *See Medtronic, Inc. v. Telectronics, Inc.*, 5 U.S.P.Q.2d (BNA) 1649 (D. Colo. 1987) (where a presumption of irreparable harm was found and successfully rebutted); *cf. E.I. duPont de Nemours & Co. v. Polaroid Graphics Imaging, Inc.*, 887 F.2d 1095 (Fed. Cir. 1989); *Southwest Aerospace Corp. v. Teledyne Indus., Inc.*, 884 F.2d 1398 (Fed. Cir. 1989); *Hybritech, Inc. v. Abbott Laboratories*, 849 F.2d 1446 (Fed. Cir. 1988); *H.H. Robertson, Co. v. United Steel Deck, Inc.*, 820 F.2d 384 (Fed. Cir. 1987); *Atlas Powder v. Ireco Chem.*, 773 F.2d 1230 (Fed. Cir. 1985); *Smith Int'l, Inc. v. Hughes Tool Co.*, 718 F.2d 1573 (Fed. Cir. 1983), *cert. denied*, 464 U.S. 996 (1988); *Pharmacia, Inc. v. Frigitronics, Inc.*, No. 84-1923 (D. Mass. Jan. 17, 1990); *Automotive Prods., plc v. Federal-Mogul Corp.*, 11 U.S.P.Q.2d (BNA) 1471 (E.D. Mich. 1989); *Sensormatic Electronics Corp. v. Minnesota Mining & Mfg. Co.*, 10 U.S.P.Q.2d (BNA) 1467 (S.D. Fla. 1988); *Zeller Plastic, Koehn, Grabner & Co. v. Joyce Molding Corp.*, 698 F. Supp. 1204 (D. N.J. 1988); *Johnson & Johnson Consumer Prods., Inc. v. Ormco Corp.*, Nos. 87-341, 87-547 (D. Del. Sept. 29, 1988); *Designs for Leisure, Ltd. v. Murrey & Sons Co.*, 9 U.S.P.Q.2d (BNA) 1159 (C.D. Cal. 1988); *American Antenna Corp. v. Wilson Antenna, Inc.*, 690 F. Supp. 924 (D. Nev. 1988); *Tri-Tech, Inc. v. Engineering Dynamics Corp.*, No. 88-0883-H (D. Mass. June 23, 1988); *Lubrizol Corp. v. Exxon Corp.*, 969 F. Supp. 302 (N.D. Ohio 1988); *Amicus, Inc. v. Post-Tension of Texas, Inc.*, 5 U.S.P.Q.2d (BNA) 1731 (S.D. Tex. 1987); *Turbo Tek Enters., Inc. v. F.P. Feature Prods., Inc.*, No. 87 C 7438 (N.D. Ill. Oct. 7, 1987); *Spalding & Evenflo Co. v. Acushnet Co.*, 2 U.S.P.Q.2d (BNA) 1070 (D. Mass. 1986); *Rexnord, Inc. v. Laitram Corp.*, 1 U.S.P.Q.2d (BNA) 1923 (E.D. Wis. 1986); *Augat, Inc. v. John Mezzalingua Assoc., Inc.*, 642 F. Supp. 506 (N.D.N.Y. 1986) (where a presumption of irreparable harm was found and not rebutted).

considered in balancing the equities between the parties.<sup>73</sup> In *Roper*, the fact that both parties no longer practiced the invention evidenced a lack of an immediate irreparable injury.<sup>74</sup> However, in *E.I. duPont de Nemours & Co. v. Polaroid Graphics Imaging, Inc.*,<sup>75</sup> the lower court found support in *Smith International, Inc.* to refute this proposition and granted a preliminary injunction, which was affirmed by the Federal Circuit.

The invention in *E.I. duPont* was a color separation process for image reproduction that was infringed by Polaroid's Spectra color proofing process.<sup>76</sup> A strong showing of validity was found from a successful reexamination of the patent and from the testimony of one of Polaroid's experts.<sup>77</sup> Combined with Polaroid's admission of infringement, irreparable harm was presumed.<sup>78</sup> Polaroid unsuccessfully argued that duPont would not suffer irreparable harm because duPont was not using the patented process commercially. The district court found that:

it is consistent with intellectual property law principles that a patent holder need not practice his invention in order to prevent others from practicing what he invented. As the Court of Appeals for the Federal Circuit explained in *Smith International*: The very nature of the patent right is the right to exclude others. Once the patentee's rights have been held to be valid and infringed, he should be entitled to the full enjoyment and protection of his patent rights. The infringer should not be allowed to continue his infringement in the face of such a holding.<sup>79</sup>

Another factor used to mitigate a showing of irreparable harm is whether the invention is presently licensed to others.<sup>80</sup> This fac-

---

73. *Cf. Kalipharma, Inc. v. Bristol-Myers Co.*, 707 F. Supp. 741 (S.D.N.Y. 1989)(where the court used evidence of the *patentee's* solvency and revenues from the successful sale of its patented product to determine that there was a lack of irreparable harm).

74. *Roper*, 757 F.2d 1266, 1273 (Fed. Cir. 1985).

75. 706 F. Supp. 1135, 1144 (D. Del.), *aff'd*, 887 F.2d 1095 (Fed. Cir. 1989).

76. *E.I. duPont, supra*, 706 F. Supp. at 1137.

77. 706 F. Supp. at 1141, 1143.

78. 706 F. Supp. at 1144.

79. *E.I. duPont de Nemours & Co. v. Polaroid Graphics Imaging, Inc.*, 706 F. Supp. 1135, 1144 (D. Del.), *aff'd*, 887 F.2d 1095 (Fed. Cir. 1989)(quoting *Smith International*, 718 F.2d at 1581); *see also* *Johnson & Johnson Consumer Prods., Inc. v. Ormco Corp.*, Nos. 87-341, 87-547 (D. Del. Sept. 29, 1988)(presumption of irreparable harm was not rebutted by the fact that the moving party was not now selling the product and therefore not losing market share).

80. *See Rosemont, Inc. v. United States Int'l Trade Comm'n*, 15 U.S.P.Q.2d (BNA) 1569 (Fed. Cir. 1990) (presumption of irreparable harm rebutted by plaintiff's grant of two licenses and its delay in seeking relief); *Illinois Tool Works Inc. v. Grip-Pak, Inc.*, 906 F.2d 679 (Fed. Cir. 1990) (lack of irreparable harm found where plaintiff had not demonstrated a reasonable likelihood of success on the merits, but had licensed its patent to another); *Crucible Materials Corp. v. Sumitomo Metals Co., Ltd.*, 719 F. Supp. 14 (D.D.C. 1989)(where nine leading manufacturers agreed to pay a license under the patent, this evidence was effectively used to support a likelihood of success on validity (acqui-

tor shows that the patent holder is only losing a portion of royalties owed due to the nonmovant's infringing activity.

Irreparable harm may also be mitigated by showing that the infringing product does not compete directly with the movant's product or is not marketed in the same geographic area as the movant's product.<sup>81</sup>

The movant's delay in seeking a preliminary injunction has often been used to rebut a charge of irreparable harm with varying success.<sup>82</sup> Although "a showing of delay does not preclude, *as a*

---

escence) and to mitigate any irreparable harm); *Fraige v. Classic Corp.*, 230 U.S.P.Q. 223 (C.D. Cal. 1985) (where several licenses were granted under the patent, the court found that irreparable injury, in the absence of an injunction, could be cured by defendant's payment into an interest bearing trust account the equivalent of 3% gross sales of infringing waterbeds); *cf. Ortho Pharmaceutical Corp. v. Smith*, 15 U.S.P.Q.2d (BNA) 1856 (E.D. Pa. 1990) (where the grant of a license was found to be indicative of industry acquiescence in the validity of the patent); *Johnson & Johnson Consumer Prods., Inc. v. Ormco Corp.*, Nos. 87-341, 87-547 (D. Del. Sept. 29, 1988) (where preliminary injunctions were granted for both patent-holding parties, district court held that the presumption of irreparable harm was not rebutted by the grant of a license for dental brackets).

81. See *Metcalfe, Preliminary Injunctions and Their Availability: How to Defend Against the Early Injunction*, 15 A.I.P.L.A. Q.J. 104, 118 (1987).

82. The patent holder's delay in seeking a preliminary injunction did not preclude a finding of irreparable harm in the following cases: *E.I. duPont de Nemours & Co. v. Polaroid Graphics Imaging, Inc.*, 887 F.2d 1095 (Fed. Cir.), *aff'g*, 706 F. Supp. 1135 (D. Del. 1989) (where a delay of about three years in bringing the suit was justified since the suit was brought after an interference proceeding was won and the defendant acquired the smaller, infringing company); *Hybritech, Inc. v. Abbott Laboratories*, 849 F.2d 1446 (Fed. Cir. 1988), *aff'g*, 4 U.S.P.Q.2d (BNA) 1001 (C.D. Cal. 1987) (where delay did not preclude a finding of irreparable harm given the movant's financial resources); *Saes Getters S.p.A. v. Ergenics, Inc.*, 15 U.S.P.Q.2d (BNA) 1212 (D.N.J. 1990) (presumption of irreparable harm not rebutted by plaintiff's seven month delay in commencing the suit and its one year delay in seeking a preliminary injunction after the suit was filed); *Pharmacia, Inc. v. Frigitronics, Inc.*, 13 U.S.P.Q.2d (BNA) 1833 (D. Mass. 1989) (where a five year delay between plaintiff's filing suit and its motion for preliminary injunction was excusable and did not rebut the presumption of irreparable harm); *Whistler Corp. v. Dynascan Corp.*, No. 88 C 8368 (N.D. Ill. Feb. 10, 1989) (where a finding of irreparable harm was not precluded by the plaintiff's delay of more than one year in filing the infringement suit while it adjudicated a separate suit that would establish the likelihood of success on the merits, however, the delay in notifying the defendant of the alleged infringement mitigated against a finding of irreparable harm); *Johnson & Johnson Consumer Prods., Inc. v. Ormco Corp.*, Nos. 87-341, 87-547 (D. Del. Sept. 29, 1988) (the court concluded that the time of bringing the motion for a preliminary injunction is *irrelevant* in considering the actual harm that will be suffered); *Amicus, Inc. v. Post-Tension of Texas, Inc.*, 686 F. Supp. 583 (S.D. Tex. 1987) (presumption of irreparable harm not rebutted by plaintiff's twenty-month delay between filing and moving for preliminary injunction because the delay was justified on the facts); *Spalding & Evenflo Co. v. Acushnet Co.*, 2 U.S.P.Q.2d (BNA) 1070 (D. Mass. 1986) (evidence showing that plaintiff delayed four and one-half years between the time of filing suit and the time of filing the motion for preliminary injunction could not, alone, prevent a finding of irreparable injury); *Rexnord, Inc. v. Laitram Corp.*, 1 U.S.P.Q.2d (BNA) 1923 (E.D. Wis. 1986) (court found justifiable reasons for plaintiff's delay in bringing preliminary injunction motion); *SMI Indus. Canada, Ltd. v. Caelter Indus., Inc.*, 586

*matter of law*, a determination of irreparable harm,"<sup>83</sup> a movant should offer some justification for its delay in seeking a preliminary injunction. Valid reasons for the delay include the patent holder's participation in an interference proceeding, a re-examination proceeding, or negotiations with the alleged infringer. A patent holder may also provide evidence showing that no economic harm existed before the suit was filed.<sup>84</sup>

---

F. Supp. 808 (N.D.N.Y. 1984) (six month delay in seeking preliminary injunction held not fatal to motion where plaintiff encountered difficulties obtaining proper documentation and the issues were relatively complex). The patent holder's delay in seeking a preliminary injunction did preclude a finding of irreparable harm in the following cases: *Rosemount, Inc. v. United States Int'l Trade Comm'n*, 15 U.S.P.Q.2d (BNA) 1569 (Fed. Cir. 1990) *Astronics Corp. v. Patecell*, 848 F.2d 1245 (Fed. Cir. 1988), *aff'g*, No. 85-1226E (W.D.N.Y. July 24, 1987) (without discussion, the Federal Circuit found no error in the lower court's conclusion that, based on the facts surrounding Patecell's delay in filing suit, there was no irreparable harm); *T.J. Smith & Nephew, Ltd. v. Consolidated Medical Equip., Inc.*, 821 F.2d 646 (Fed. Cir. 1987), *aff'g*, 645 F. Supp. 206 (N.D.N.Y. 1986) (delay of fifteen months was one of six factors supporting finding of no irreparable harm); *Datascope Corp. v. Kontron, Inc.*, 786 F.2d 398 (Fed. Cir. 1986), *aff'g*, 611 F. Supp. 889 (D. Mass. 1985) (where the plaintiff could not show irreparable harm due to a three and one-half year delay in bringing suit and the lack of proof of defendant's inability to pay damages); *Ampex Corp. v. Obekas Video Sys., Inc.*, 15 U.S.P.Q.2d (BNA) 1219 (N.D. Cal. 1990) (where defendant marketed its accused products in 1984 and 1986 but plaintiff did not seek preliminary relief until 1989); *Crucible Materials Corp. v. Sumitomo Special Metals Co.*, 719 F. Supp. 14 (D.D.C. 1989) (three year delay in bringing suit after infringing activity began supported finding of no irreparable harm even though the delay was caused by a dispute with a licensee and the hope of a successful negotiation with the alleged infringer); *Kalipharma, Inc. v. Bristol-Myers Co.*, 707 F. Supp. 741 (S.D.N.Y. 1989) (lack of irreparable harm found where patent holder delayed seven months from the date the action was filed before seeking an injunction, knowing that the alleged infringer was actively taking steps to market the claimed drug and the patent holder moved more expeditiously in a prior suit against a different challenger); *Russell William, Ltd. v. ABC Display & Supply, Inc.*, 11 U.S.P.Q.2d (BNA) 1812 (E.D.N.Y. 1989) (the plaintiff was not entitled to a presumption of irreparable harm where the delay in seeking speedy relief was two years from the time plaintiff was aware of the infringement and where the delay was not due to a resolution attempt, fraud by the defendant, or an inability to determine infringement); *Archive Corp. v. Cipher Prods. Inc.*, 12 U.S.P.Q.2d (BNA) 1464 (C.D. Cal. 1988) (delay of less than two years from patent issuance in seeking relief was found indicative of a lack of irreparable harm even though a portion of that time was spent pursuing another defendant); *Medtronic, Inc. v. Telectronic, Inc.*, 686 F. Supp. 838, 5 U.S.P.Q.2d (BNA) 1649 (D. Colo. 1987) (defendant rebutted the presumption of irreparable harm with evidence of plaintiff's five-year delay in bringing suit); *Rexnord, Inc. v. Laitram Corp.*, 628 F. Supp. 467 (E.D. Wis. 1986) (patent holder could not prove irreparable harm due to their sixteen-month delay in bringing suit); *Unique Concepts, Inc. v. Manuel*, 231 U.S.P.Q. (BNA) 268 (N.D. Ill. 1986) (irreparable harm was not proved where the plaintiff knew of the alleged infringement one or two years before filing suit).

83. *Hybritech, Inc. v. Abbott Laboratories*, 849 F.2d 1446, 1457 (Fed. Cir. 1988), *aff'g* 4 U.S.P.Q.2d 1001 (BNA) (C.D. Cal. 1987) (footnote omitted).

84. See *E.I. duPont de Nemours & Co. v. Polaroid Graphics Imaging, Inc.*, 887 F.2d 1095 (Fed. Cir.), *aff'g* 706 F. Supp. 1135, 1145 (D. Del. 1989) (three or more year delay excused); *Illinois Tool Works, Inc. v. Grip-Pak, Inc.*, 725 F.

In *E.I. duPont de Nemours & Co. v. Polaroid Graphics Imaging, Inc.*, the patent holder was justified in not bringing an infringement suit against a small company using the patented color proofing process while the patent was involved in re-examination and interference proceedings. There was no *economic reason* for duPont to take action until Polaroid acquired the small company and until sales from using the infringing process increased from about \$500,000 to roughly \$3 million.<sup>85</sup>

Preliminary injunctions have been granted where patentees have justified delays of four to five years.<sup>86</sup> In *Spalding & Evenflo Co. v. Acushnet Co.*,<sup>87</sup> the plaintiff demonstrated immediate irreparable harm by submitting evidence that the accused golf balls halted plaintiff's market penetration and expansion as well as adversely affected plaintiff's market share for related goods.

A five-year delay between filing the suit and moving for a preliminary injunction was calculated by the accused infringer in *Pharmacia, Inc. v. Frigitrionics, Inc.*<sup>88</sup> The district court found that this calculation was wrong in light of a jointly-requested stay that was in effect during roughly half of that five-year period and in light of the fact that the patentee moved for preliminary relief shortly after a successful reexamination. According to the court, the actual delay was then the twenty-six months before the stay.<sup>89</sup>

Several reasons justified why the patent holder in *Pharmacia* did not seek a preliminary injunction earlier: (1) at that time the trial was set for an earlier date; (2) there was a lesser potential of other infringers entering the fray; (3) there was a greater likelihood that the accused infringer would be able to satisfy any award of damages; and (4) the patent was upheld after an extensive re-examination by the Patent and Trademark Office.<sup>90</sup>

Irreparable harm may be supported by the following independent factors: (1) the field of technology covered by the patent is new; (2) substantial competition exists in the field; (3) the accused infringer maintains a large presence in the field; (4) the field is changing quickly; (5) a significant amount of research is being done in this field; (6) the patent could help the movant establish market posi-

---

Supp. 951 (N.D. Ill. 1989) (plaintiff's six year delay in bringing suit was excused because the defendant's activities were not commercially significant then).

85. 706 F. Supp. at 1145.

86. See *Pharmacia, Inc. v. Frigitrionics, Inc.*, 13 U.S.P.Q.2d (BNA) 1833 (D. Mass. 1990) (preliminary injunction granted after five year delay); *Spalding & Evenflo Co. v. Acushnet Co.*, 2 U.S.P.Q.2d (BNA) 1070 (D. Mass. 1986) (preliminary injunction granted after four and one-half year delay).

87. 2 U.S.P.Q.2d (BNA) 1070, 1071 (D. Mass. 1986).

88. No. 84-1923, slip op. at 23 (D. Mass. Jan. 17, 1990) (motion for preliminary injunction granted).

89. *Id.* at 23-24.

90. *Id.* at 24.

tion; (7) the value of the patent may vanish by the time the litigation is completed; (8) potential injury to the movant is unpredictable; and (9) others may be encouraged to infringe in the absence of an injunction.<sup>91</sup>

### *Balance of Hardships*

In balancing the threatened injuries that both parties face from the issuance or nonissuance of a preliminary injunction, courts are no longer sympathetic to the harms facing the accused infringer from a disruption of the infringing activity.<sup>92</sup>

---

91. See *Hybritech, Inc. v. Abbott Laboratories*, 849 F.2d 1446 (Fed. Cir. 1988), *aff'g* 4 U.S.P.Q.2d (BNA) 1001 (C.D. Cal. 1987) (where irreparable harm was presumed, but the court cited several other factors supporting a finding of irreparable harm).

92. In *Augat, Inc. v. John Mezzalingua Assoc. Inc.*, 642 F. Supp. 506, 508-09 (N.D.N.Y. 1986) the plaintiff held a patent for a coaxial connector and competed directly against the accused infringer. The district court found that the balance of the hardships weighed in favor of the plaintiff irrespective of the hardships facing the defendant (i.e. employee layoffs and idle manufacturing equipment). The plaintiff's ability to continue to enjoy large sales, and the fact that other companies' coaxial connectors compete with plaintiff's products tipped the scales. *Id.*

Although the infringer was apparently on the market for two years before the patent issued, and the preliminary injunction motion was made some three years after the patent issued. The court nevertheless declared that:

Defendant has no legal right to continue to profit from sales which appear at this stage in the litigation to infringe plaintiff's patent. To the extent the preliminary injunction poses a hardship to defendant because it has become excessively dependent on sales of its coaxial connector this poses no bar to the issuance of an injunction where it appears that these sales infringe plaintiff's patent rights. Rather, halting defendant's unauthorized use of plaintiff's patent is consistent with the Federal Circuit's view that trespasses should be halted "cold turkey."

*Augat, Inc.*, 642 F. Supp. at 509 (citing *Atlas Powder*, 773 F.2d 1230, 1232 (Fed. Cir. 1985)).

The Federal Circuit expressed this same sentiment where a district court denied a permanent injunction against an infringer because the injunction would devastate the small competitor. Admonishing the lower court for abusing its discretion, the circuit court explained that "[o]ne who elects to build a business on a product found to infringe cannot be heard to complain if an injunction against continuing infringement destroys the business so elected." *Windsurfing Int'l v. AMF, Inc.*, 782 F.2d 995, 1003 n.12 (Fed. Cir.), *cert. denied sub nom. Bic Leisure Products, Inc. v. Windsurfing Int'l*, 106 S. Ct. 3275 (1986). *Cf. Illinois Tool Works Inc. v. Grip-Pak, Inc.*, 15 U.S.P.Q.2d (BNA) 1307, 1310-11 (Fed. Cir. 1990) (where the Federal Circuit stated that this quote from *Windsurfing, supra*, was inappropriate in the context of a preliminary injunction motion).

*P.W. Woo & Sons, Inc. v. Antelope Enter. Co.*, 871 F.2d 1096, 10 U.S.P.Q.2d (BNA) 1876 (Fed. Cir. 1989), *aff'g* No. 87-6848 (C.D. Cal. Aug. 15, 1988), is another example of the judicial insensitivity to an accused infringer's plight. In *P.W. Woo*, the district court considered evidence that the defendant held \$500,000 worth of inventory that could not be sold in face of the injunction. However, the court found the balance in favor of the plaintiff whose irreparable harm included lost sales that could not be calculated, damages the defendant

In *Atlas Powder*, the Federal Circuit rejected the accused infringer's argument that a balance of the hardships is reached by returning the state of affairs to that existing before the litigation commenced.

[A]uthorizing the wrongdoer to continue the wrong, only not at an increased rate, is in no realistic sense maintaining the status quo.

\* \* \*

[A] preliminary injunction preserves the status quo if it prevents future trespasses but does not undertake to assess the pecuniary or other consequences of past trespasses. [If the infringing party] has allowed itself to become excessively dependent upon infringing sales, the status quo catchword does not necessarily allow it to continue such dependence, apart from other factors. The concept is not inconsistent with stopping trespasses 'cold turkey.'<sup>93</sup>

In *American Parking*, the patentee's device was not commercially successful; the competing product, on the other hand, had a "chance of a better future" with a \$50,000 per month contract with

---

could not pay, lost profits which could not be calculated, and damage to the plaintiff's reputation. 10 U.S.P.Q.2d at 1876.

In *Upjohn Co. v. Medtrom Laboratories, Inc.*, 751 F. Supp. 416 (S.D.N.Y. 1990) (unpublished disposition), the defendants' revenues were derived entirely from the sale of its accused product. Nevertheless, the court found the balance of hardships in favor of the plaintiff and suggested that the defendants could purchase the topical drug from the plaintiff in order to treat their customers.

A number of district courts continue to consider the accused infringer's losses due to sales of the infringing product in balancing the hardships. See *Illinois Tool Works, Inc. v. Grip-Pak, Inc.*, 725 F. Supp. 951 (N.D. Ill. Dec. 4, 1989), *aff'd*, 15 U.S.P.Q.2d (BNA) 1307 (Fed. Cir. 1990) (where the balance tipped in the defendant's favor because an injunction might destroy the defendant's business whereas the patentee's business would only be less profitable if the injunction were denied); see also *Drexelbrook Controls, Inc. v. Magnetrol Int'l, Inc.*, 720 F. Supp. 397 (D. Del. 1989), *aff'd*, 16 U.S.P.Q.2d (BNA) 1158 (Fed. Cir. 1990); *Ampex Corp. v. Abekas Video Sys., Inc.*, 15 U.S.P.Q.2d (BNA) 1219 (N.D. Cal. 1990) (where an injunction would reduce defendant's revenues by 50%); *Crucible Materials Corp. v. Sumitomo Metals Co.*, 719 F. Supp. 14 (D.D.C. 1989); *Kalipharma, Inc. v. Bristol-Myers Co.*, 707 F. Supp. 741 (S.D.N.Y. 1989).

Although the balance of hardships was found to favor the patentee in *Drexelbrook Controls, Inc.*, it was only because revenue derived from sales of the infringing product constituted a relatively small percentage of the accused infringer's total sales.

In *Crucible Materials*, the District Court of the District of Columbia found that the balance tipped in favor of the accused infringer because an injunction would disrupt the expectations of third parties who had contracted with the accused infringer before the suit was filed.

In *Kalipharma, Inc.*, the patentee spent \$33 million on research and development of the claimed drug while the accused infringer spent \$1.5 million. Nevertheless, the district court held that based on overall revenue, the accused infringer's loss would be a greater *percentage* of its sales than the patentee's loss.

93. *Atlas Powder Co. v. Ireco Chem.*, 773 F.2d 1230, 1231-32 (Fed. Cir. 1985) (where the allegedly infringing products accounted for 66% of the defendant's total sales, the injunction would force a lay-off of approximately 200 employees, and the patent-in-suit was to expire within a year).



the City of Philadelphia.<sup>94</sup> The district court found that "commercially, in the short run at least, defendants will suffer more greatly than the plaintiff."<sup>95</sup> In balancing the harms, however, the court found in favor of the patentee. The court explained that

financial loss is not all that must [be] consider[ed] . . . . Delay may well become the equivalent of an involuntary license by the patent holder. Manufacture and sale of what is apparently an infringing product is irreparable harm. If the patent is valid and no injunction should issue, there would be a loss of good will and potential revenue on plaintiff's part.<sup>96</sup>

### Public Interest

The early federal court focus was on the public interest in free competition and the public distrust of monopolies. Condoning infringing activity in the name of free competition, however, frustrated the Congressional intent of securing short-term exclusions for novel, useful and nonobvious inventions.<sup>97</sup>

Today, public interest is frequently found in favor of protecting the patent holder's rights.<sup>98</sup>

---

94. *American Parking Meter Advertising, Inc. v. Visual Media, Inc.*, 693 F. Supp. 1253, 1254 (D. Mass. 1987).

95. *Id.* at 1255.

96. *Id.* (citation omitted).

97. *See Eli Lilly & Co. v. Premo Pharmaceutical Labs*, 630 F.2d 120, 137 (3rd Cir. 1980).

98. *See Rosemount, Inc. v. United States Int'l Trade Comm'n*, 15 U.S.P.Q.2d (BNA) 1569 (Fed. Cir. 1990); *E.I. duPont de Nemours & Co. v. Polaroid Graphics Imaging, Inc.*, 887 F.2d 1095 (Fed. Cir. 1989); *Southwest Aerospace Corp. v. Teledyne Indus., Inc.*, 884 F.2d 1398 (Fed. Cir. 1989); *Dreamlite Holdings, Ltd. v. Kraser*, 12 U.S.P.Q.2d (BNA) 1574 (Fed. Cir. 1989); *Hybritech, Inc. v. Abbott Laboratories*, 849 F.2d 1446 (Fed. Cir. 1988); *American Parking Meter Advertising, Inc. v. Visual Media, Inc.*, 848 F.2d 1244 (Fed. Cir. 1988); *Smith Int'l, Inc. v. Hughes Tool Co.*, 718 F.2d 1573 (Fed. Cir. 1983), *cert. denied*, 464 U.S. 996; *Saes Getters S.P.A. v. Ergenics, Inc.*, No. 89-649 (D. N.J. July 30, 1990); *Oscar Mayer Foods Corp. v. Sara Lee Corp.*, 743 F. Supp. 1326 (W.D. Wis. 1990); *Saes Getters S.P.A. v. Ergenics, Inc.*, 15 U.S.P.Q.2d (BNA) 1212 (D. N.J. 1990); *Oscar Mayer Foods Corp. v. Sara Lee Corp.*, 15 U.S.P.Q.2d (BNA) 1204 (W.D. Wis. 1990); *Ortho Pharmaceutical Corp. v. Smith*, 15 U.S.P.Q.2d (BNA) 1856 (E.D. Pa. 1990); *Pharmacia, Inc. v. Frigitronics, Inc.*, No. 84-1923 (D. Mass. Jan. 17, 1990); *Moore Business Forms, Inc. v. Wallace Computer Services, Inc.*, 14 U.S.P.Q.2d (BNA) 1849 (N.D. Ind. 1989); *We Care, Inc. v. Ultra Mark Int'l Corp.*, 14 U.S.P.Q.2d (BNA) 1804 (D. Minn. 1989); *Biocraft Laboratories v. Bristol-Myers Co.*, No. 89-158 (D. N.J. Feb. 24, 1989); *Automotive Products, plc v. Federal-Mogul Corp.*, 11 U.S.P.Q.2d (BNA) 1471 (E.D. Mich. 1989); *Sensormatic Elecs. Corp. v. Minnesota Mining & Mfg. Co.*, 10 U.S.P.Q.2d (BNA) 1467 (S.D. Fla. 1988); *Zeller Plastik, Koehn, Grabner & Co. v. Joyce Molding Corp.*, 698 F. Supp. 1204 (D. N.J. 1988); *Johnson & Johnson Consumer Prods., Inc. v. Ormco Corp.*, Nos. 87-341, 87-547 (D. Del. Sept. 29, 1988); *Designs for Leisure, Ltd. v. Murrey & Sons Co.*, 9 U.S.P.Q.2d (BNA) 1159 (C.D. Cal. 1988); *American Antenna Corp. v. Wilson Antenna, Inc.*, 690 F. Supp. 924 (D. Nev. 1988); *Tri-Tech, Inc. v. Engineering Dynamics Corp.*, 8 U.S.P.Q.2d (BNA) 1371 (D. Mass. 1988); *Lubrizol Corp. v. Exxon Corp.*, 696 F. Supp. 302 (N.D. Ohio 1988); *Toro Co. v. Textron Inc.*, 5 U.S.P.Q.2d (BNA) 1616 (W.D.N.C. 1987); *Turbo Tek Enters., Inc.*

The public interest in a patent case is strongly weighted toward protecting the rights of patent holders. Defendant argue[d] that the public interest is in favoring free and full competition. Generally, this is so in our free market system, but patents are a clear exception to this rule: patent law protects inventors in assuring that inventors and patent holders will enjoy financial protection in marketing their invention.<sup>99</sup>

While upholding patent rights, the courts may still decline to enjoin an infringer in a medically-related field where the accused invention is a superior medical device<sup>100</sup> or helps to fill a public demand that cannot be met by the patent holder's current manufacturing capacity.<sup>101</sup> The public interest in lower-priced, generic drugs, however, does not automatically trump the public interest in intellectual property rights.<sup>102</sup>

#### STRATEGIES AND CAUTIONS FOR THE CURRENT BATTLEFIELD

One of the perceived advantages of making preliminary injunctions more easily obtainable by patent holders is the ability to hasten patent infringement litigation under Rule 65, Federal Rules

---

v. F.P. Feature Products, Inc., No. 87 C 7438 (N.D. Ill. Oct. 7, 1987); John Fluke Mfg. v. North Am. Soar Corp., 5 U.S.P.Q.2d (BNA) 1657 (D. N.J. 1987); Pittway Corp. v. Black & Decker, Inc., 667 F. Supp. 585 (N.D. Ill. 1987); Upjohn Co. v. Riahom Corp., 641 F. Supp. 1209 (D. Del. 1986); Rexnord, Inc. v. Laitram Corp., 1 U.S.P.Q.2d (BNA) 1923 (E.D. Wis. 1986); Unique Concepts, Inc. v. Manuel, 231 U.S.P.Q. (BNA) 268 (N.D. Ill. 1986); Imi-Tech Corp. v. Gagliani, 691 F. Supp. 214 (S.D. Cal. 1986); Medeco Security Locks, Inc. v. Cinquini, 229 U.S.P.Q. (BNA) 398 (D. Mass. 1985).

99. *Augat*, 642 F. Supp. at 509 (citing *Smith Int'l, Inc.*, 718 F.2d at 1581, 1577-78).

100. *Pharmacia, Inc. v. Frigitronics, Inc.*, 726 F. Supp. 876, 13 U.S.P.Q.2d 1833 (D. Mass. 1990).

101. *Hybritech, Inc. v. Abbott Laboratories*, 849 F.2d 1446 (Fed. Cir. 1988).

102. See *Bristol-Myers Co. v. United States Int'l Trade Comm'n*, 892 F.2d 1050 (Fed. Cir. 1989), *rev'g* Inv. No. 337-TA-293 (I.T.C. June 13, 1989) (text of opinion available on WESTLAW). The International Trade Commission denied Bristol-Myers' motion for a preliminary injunction against manufacturers and importers of a patented crystalline form of cefadroxil — a higher bulk density form of the antibiotic which enables the production of smaller pills. The Federal Circuit reversed, stating that:

[w]hile the ALJ found that the public interest in cheaper drugs outweighed any adverse effect on Bristol-Myers, we believe that the analysis is more complex than here made. The policy considerations governing the right of a patentee to exclude infringers are embodied in the patent laws, and it is the protection of valid patent and other intellectual property rights that is the principal public policy implemented by [19 U.S.C.] § 1337. This policy is reinforced by the recent [1988] amendments to 19 U.S.C. § 1337(e), designed . . . to facilitate preliminary relief. *Id.*

The recently enacted provision referenced, 19 U.S.C. § 1337(e)(3) (1988), certified the Commission's authority with respect to preliminary relief; The Commission may grant preliminary relief under this subsection or subsection (f) to the same extent as preliminary injunctions and temporary restraining orders may be granted under the Federal Rules of Civil Procedure. *Id.*, slip op. at 1.

of Civil Procedure.<sup>103</sup> This is a particularly timely concern when civil jury calendars are expected to be "on hold in most metropolitan areas no later than two years from now."<sup>104</sup>

A recent district court case illustrates the usefulness of this procedural tool. In *Joslyn Manufacturing Co. v. Amerace Corp.*,<sup>105</sup> the patentee moved for a preliminary injunction in its infringement suit against a second defendant.<sup>106</sup> The district court, concerned that a hearing on the preliminary injunction motion would effectively require the court to try the case twice,<sup>107</sup> set an early trial without making a decision on the plaintiff's preliminary injunction motion.<sup>108</sup>

By moving for a preliminary injunction, the patent holder can put pressure on the defendant to settle given the following factors: (1) the frequency in which preliminary injunctions are granted;<sup>109</sup> (2) the infrequency in which preliminary injunctions are stayed pending an appeal;<sup>110</sup> (3) the fact that preliminary injunctions are rarely reversed;<sup>111</sup> and (4) the fact that a preliminary injunction can be dispositive of the case irrespective of the difficulty in demon-

103. Now that preliminary injunctions are actually available to patent holders, patent holders may invoke Rule 65(a)(2), FED.R.CIV.P. for expediting a case on a notoriously crowded civil docket. Under Rule 65, "[b]efore or after the commencement of the hearing of an application for a preliminary injunction, the court may order the trial of the action on the merits to be advanced and consolidated with the hearing of the application." Rule 65(a)(2), FED.R.CIV.P.

104. Note, *Attorneys Describe ADR Use in Antitrust and Patent Controversies*, 3 A.D.R. REPORT 403 (1989)(quoting Robert D. Raven, immediate past president of the American Bar Association, on November 9, 1989).

105. No. 89 C 5775 (N.D. Ill. Mar. 15, 1990).

106. *Id.* A settlement had been reached in a separate suit against the first defendant.

107. *Id.* Once in a hearing on the preliminary injunction and again at trial.

108. *Id.*

109. Since October of 1983, patent holders have been entitled to a preliminary injunction in the Federal Circuit and federal district courts in 60% of the cases coming before those courts.

110. See *American Parking Meter Advertising, Inc. v. Visual Media, Inc.*, 848 F.2d 1244 (Fed. Cir. 1988), slip op. at 4, *aff'g* 693 F. Supp. 1253 (D. Mass. 1987) (text of opinion available on WESTLAW) ("A preliminary injunction is effective only during the litigation and to stay it pending appeal would be to effectively deny it, which is the opposite of our decision."); see also *Biocraft Laboratories, Inc. v. Bristol-Myers Co.*, No. 89-158 (D. N.J. Feb. 24, 1989) (motion for 30-day stay to complete experiments to disprove patentee's invention denied). But see *Hybritech, Inc. v. Abbott Laboratories*, 849 F.2d 1446 (Fed. Cir. 1988) (injunction stayed pending appeal to Federal Circuit); *Power Controls Corp. v. Hybrinetics, Inc.*, 806 F.2d 234 (Fed. Cir. 1986) (original injunction stayed by Federal Circuit; modified injunction granted subsequently).

111. Out of 29 patent preliminary injunction cases appealed to the Federal Circuit, in not one instance did the Federal Circuit reverse a lower court's grant of a preliminary injunction. The Federal Circuit did, however, vacate a lower court's affirmative decision on a motion in four of those cases, but those holdings were due to an insufficient factual basis for the injunction in the lower court's opinion.

strating noninfringement.<sup>112</sup>

Another reason for advising patent holders to seek a preliminary injunction is to make an early assessment of the strengths and weaknesses of the alleged infringer's case, as well as the patent holder's own case. In addition, a summary judgment may also be sought after the preliminary injunction has been decided.

One disadvantage to obtaining a preliminary injunction in a patent infringement suit is that the patentee may be required to post a substantial security bond as a condition of the order granting the preliminary injunction.<sup>113</sup>

There are also several disadvantages associated with an unfavorable decision on a patent holder's preliminary injunction motion. First, the unfavorable reaction of the district judge may be hard to dispel during the trial. Second, third parties would be encouraged to infringe if the patent holder lost on its motion. Third, an unfavorable opinion might well have to be explained in any subsequent litigation and would be constantly referred to by the opposing party.

#### CONCLUSION

In light of the revolutionary changes made in the rules of battle by the Federal Circuit in patent preliminary injunction cases, patent holders should consider supplementing their patent infringement actions with a preliminary injunction motion. Not only is the likelihood of success in getting an injunction greater than ever

---

112. See Metcalf, *Preliminary Injunctions and Their Availability: How to Defend Against the Early Injunction*, 15 A.I.P.L.A. Q. J. 104, 105-06 (1987).

113. Application Art Laboratories Co. v. Morita, 13 U.S.P.Q.2d (BNA) 1254 (Fed. Cir. 1989) (\$100,000 bond); American Parking Meter Advertising, Inc. v. Visual Media, Inc., 848 F.2d 1244 (Fed. Cir. 1988) (unpublished disposition) (\$500,000 bond); Saes Getters S.P.A. v. Ergenics, Inc., No. 89-649 (D.N.J. July 30, 1990) (\$125,000 bond); Seas Getters S.P.A. v. Ergenics, Inc., 15 U.S.P.Q.2d (BNA) 1212 (D. N.J. 1990) (\$125,000 bond); Moore Business Forms, Inc. v. Wallace Computer Services, Inc., 14 U.S.P.Q.2d (BNA) 1849 (N.D. Ill. 2d 1989) (\$500,000 bond); Biocraft Laboratories v. Bristol-Myers Co., No. 89-158 (D.N.J. Feb. 24, 1989) (\$1 million bond); Lubrizol Corp. v. Exxon Corp., 696 F. Supp. 302 (N.D. Ohio 1988) (\$100,000 bond); Amicus, Inc. v. Post-Tension of Texas, Inc. 686 F. Supp. 583 (S.D. Tex. 1987) (\$350,000 bond); Turbo Tek Enter., Inc. v. F. P. Feature Products, Inc., No. 87 C 7438 (N.D. Ill. Oct. 7, 1987) (\$50,000 bond); John Fluke Mfg. v. North American Soar Corp., 5 U.S.P.Q.2d (BNA) 1657 (D. N.J. 1987) (\$200,000); Westhem Corp. v. Poly-Seal Corp., 4 U.S.P.Q.2d (BNA) 1534 (D. Md. 1986) (\$100,000 bond set in design patent case); Rexnord, Inc. v. Laitram Corp., 1 U.S.P.Q.2d (BNA) 1923 (E.D. Wis. 1986) (\$80,000 bond); Augat, Inc. v. John Mezzalingua Assoc., Inc., 642 F. Supp. 506 (N.D.N.Y. 1986) (\$360,000 bond); Imi-Tech Corp. v. Gagliani, 691 F. Supp. 214 (S.D. Cal. 1986) (\$100,000 bond); Glasstech, Inc. v. AB Kyro OY, 635 F. Supp. 465 (N.D. Ohio 1986) (\$500,000 bond); Medeco Security Locks, Inc. v. Cinquini, 229 U.S.P.Q. (BNA) 398 (D. Mass. 1985) (\$1,000 bond); Fraige v. Classic Corp., 230 U.S.P.Q. (BNA) 223 (C.D. Cal. 1985) (\$5,000 bond); Gravity Guidance, Inc. v. Weseman, 220 U.S.P.Q. (BNA) 1038 (D. Minn. 1983)(\$30,000 bond).

before, but also the time required to get a trial may be reduced by using Rule 65(a)(2), Federal Rules of Civil Procedure. Indeed, in some jurisdictions, because of court congestion, it may be the only way to get the attention of the court at all. Furthermore, the likelihood that a preliminary injunction granted by a district court will be reversed on appeal or stayed pending appeal<sup>114</sup> is slim.

---

114. See *American Parking Meter Advertising, Inc. v. Visual Media, Inc.*, 848 F.2d 1244 (Fed. Cir. 1988), slip op. at 4, *aff'g* 693 F. Supp. 1253 (D. Mass. 1987) ("A *preliminary* injunction is effective only during the litigation and to stay it pending appeal would be to effectively deny it, which is the opposite of our decision."); see also *Allied-Signal, Inc. v. Filmtec Corp.*, No. 286 (Fed. Cir. June 6, 1990) (motion for stay of preliminary injunction pending appeal denied and affirmed even though the enjoined product constituted 89-95 percent of defendant's revenue); *Biocraft Laboratories, Inc. v. Bristol-Myers Co.*, No. 89-158 (D.N.J. Feb. 24, 1989) (motion for 30-day stay to complete experiments to disprove patentee's invention denied); *but see Hybritech, Inc. v. Abbott Laboratories*, 849 F.2d 1446 (Fed. Cir. 1988) (injunction stayed pending appeal to Federal Circuit); *Power Controls Corp. v. Hybrinetics, Inc.*, 806 F.2d 234 (Fed. Cir. 1986) (original injunction stayed by Federal Circuit; modified injunction granted subsequently).

## APPENDIX 1

Patent Preliminary Injunction Cases Decided Since *Smith Int'l, Inc. v. Hughes Tool Co.*, 718 F.2d 1573 (Fed. Cir. 1983), *cert. denied*, 464 U.S. 996 (1988)†

## A. FEDERAL CIRCUIT CASES:

1. *Gerber Garment Technology, Inc. v. Lectra Sys., Inc.*, 916 F.2d 683, 16 U.S.P.Q.2d (BNA) 1436 (Fed. Cir. 1990), *aff'g* 699 F. Supp. 1576, 9 U.S.P.Q.2d (BNA) 1809 (N.D. Ga. 1988) (motion for preliminary injunction denied and summary judgment on the issue of invalidity granted).
2. *McAulay v. United States Banknote Corp.*,\* 918 F.2d 185 (Fed. Cir. 1990) (table), *aff'g* 891 F.2d 298, 13 U.S.P.Q.2d (BNA) 1990 (1990) (orders granting and denying motions for preliminary injunctions).
3. *Rosemont, Inc. v. United States Int'l Trade Comm'n*, 910 F.2d 819, 15 U.S.P.Q.2d (BNA) 1569 (Fed. Cir. 1990), *aff'g* Inv. No. 337-TA-304 (March 19, 1990) (motion for temporary relief under 19 U.S.C. § 1337 denied).
4. *Chrysler Motors Corp. v. Auto Body Panels of Ohio, Inc.*, 908 F.2d 951, 15 U.S.P.Q.2d (BNA) 1496 (Fed. Cir. 1990), *aff'g* 12 U.S.P.Q.2d (BNA) 1493 (S. D. Ohio 1989) (motion for preliminary injunction on DESIGN PATENT denied).
5. *Illinois Tool Works, Inc. v. Grip-Pak, Inc.*, 906 F.2d 679, 15 U.S.P.Q.2d (BNA) 1307 (Fed. Cir. 1990), *aff'g* 725 F. Supp. 951 (N.D. Ill. 1989) (motion for preliminary injunction denied).
6. *Drexelbrook Controls, Inc. v. Magnetrol Int'l, Inc.*,\* 904 F.2d 45 (Table), 16 U.S.P.Q.2d (BNA) 1158 (Fed. Cir. 1990) (unpublished disposition), *aff'g* 720 F. Supp. 397 (D. Del. 1989) (motion for preliminary injunction denied).
7. *Yeu v. Kim*,\* 904 F.2d 44 (Table) (Fed. Cir. 1990) (affirming motion granting preliminary injunction).
8. *Application Art Laboratories Co. v. Morita*,\* 13 U.S.P.Q.2d (BNA) 1254 (Fed. Cir. 1989) (unpublished

---

† In reverse chronological order.

\* Rule 18 opinions designated as unpublished are not employed as precedent by the Federal Circuit and they cannot be cited by counsel as precedent except in support of a claim of *res judicata*, etc. A party on motion may request that an unpublished opinion be reissued as a published opinion.

- disposition), *aff'g* Nos. 84-3894 and 85-2539 (D.D.C. Jan. 11, 1989) (motion to dissolve preliminary injunction on DESIGN PATENT entered on October 7, 1988 denied).
9. *Bristol-Myers Co. v. United States Int'l Trade Comm'n*,\* No. 89-1530 (Fed. Cir. Dec. 8, 1989) (unpublished disposition), *rev'g* Inv. No. 337-TA-293 (I.T.C. June 3, 1989) (request for preliminary injunction denied).
  10. *Neiss v. A.L.C. Co.*,\* 889 F.2d 1100 (Fed. Cir. 1989) (unpublished disposition), *vacating* No. C88-3997A (N.D. Ohio Nov. 8, 1988) (order granting preliminary injunction).
  11. *Black & Decker, Inc. v. Hoover Service Center*, 886 F.2d 1285 (Fed. Cir. 1989), *vacating* No. H-87-851 (D. Conn. Jan. 27, 1989) (motion for preliminary injunction denied).
  12. *E.I. duPont de Nemours & Co. v. Polaroid Graphics Imaging, Inc.*,\* 887 F.2d 1095 (Fed. Cir. 1989) (unpublished disposition), *aff'g* 706 F. Supp. 1135 (D. Del. 1989) (order granting preliminary injunction).
  13. *Southwest Aerospace Corp. v. Teledyne Indus., Inc.* 884 F.2d 1398 (Fed. Cir. 1989) (unpublished disposition), *aff'g* 702 F. Supp. 870 (N.D. Ala. 1988) (order granting preliminary injunction).
  14. *Astro-Med, Inc. v. Western Graphtec, Inc.*,\* 878 F.2d 1447 (Fed. Cir. 1989) (unpublished disposition), *aff'g* No. 88-3348 (C.D. Cal. Oct. 20, 1988) (motion for preliminary injunction denied).
  15. *C.R. Bard, Inc. v. The Kendall Co.*,\* 878 F.2d 1446 (Fed. Cir. 1989) (unpublished disposition), *vacating* No. 88-3236 TJH (C.D. Cal. Sept. 19, 1988) (order granting preliminary injunction).
  16. *Garel Skatebike Int'l, Inc. v. Lerun Indus., Inc.*,\* 871 F.2d 1097, 10 U.S.P.Q.2d (BNA) 1639 (Fed. Cir. 1989) (unpublished disposition) (affirming motion denying preliminary injunction).
  17. *P.W. Woo & Sons Inc. v. Antelope Enterprise Co. Ltd.*,\* 871 F.2d 1096, 10 U.S.P.Q.2d (BNA) 1876 (Fed. Cir. 1989) (unpublished disposition), *aff'g* No. 87-6848 (C.D. Cal.) (Aug. 15, 1988) (order granting preliminary injunction).
  18. *Hybritech Inc. v. Abbott Laboratories*, 849 F.2d 1446, 7 U.S.P.Q.2d (BNA) 1191 (Fed. Cir. 1988), *aff'g* 4

- U.S.P.Q.2d (BNA) 1001 (C.D. Cal 1987) (order granting preliminary injunction).
19. *Astronics Corp. v. Patecell*,\* 848 F.2d 1245 (Fed. Cir. 1988) (unpublished disposition), *aff'g* No. 85-1226E (W.D.N.Y. July 24, 1987) (denial of motion for preliminary injunction).
  20. *American Parking Meter Advertising, Inc. v. Visual Media, Inc.*,\* 848 F.2d 1244 (Fed. Cir. 1988) (unpublished disposition), *aff'g* 6 U.S.P.Q.2d (BNA) 1813 (D. Mass. 1987) (order granting preliminary injunction).
  21. *Pretty Punch Shoppettes, Inc. v. Hauk*, 844 F.2d 782, 6 U.S.P.Q.2d (BNA) 1563 (Fed. Cir. 1988), *vacating* No. 87-667-CIV-T 17A (M.D. Fla. May 29, 1987) (denial of motion for preliminary injunction).
  22. *T.J. Smith and Nephew, Ltd. v. Acme United Corp.*,\* 846 F.2d 78 (Fed. Cir. 1988) (unpublished disposition) (affirming order granting preliminary injunction).
  23. *T.J. Smith and Nephew, Ltd. v. Consolidated Medical Equip. Inc.*, 821 F.2d 646, 3 U.S.P.Q.2d (BNA) 1316 (Fed. Cir. 1987), *aff'g* 3 U.S.P.Q.2d (BNA) 1129 (N.D.N.Y. 1986) (motion for preliminary injunction denied).
  24. *H.H. Robertson, Co. v. United Steel Deck, Inc.*, 820 F.2d 384, 2 U.S.P.Q.2d (BNA) 1926 (Fed. Cir. 1987), *aff'g* No. 84-5357 (D. N.J. Mar. 31, 1986) (order granting preliminary injunction).
  25. *Power Controls Corp. v. Hybrinetics, Inc.*, 806 F.2d 234, 231 U.S.P.Q. (BNA) 774 (Fed. Cir. 1986) (vacating in part order granting preliminary injunction on DESIGN PATENT).
  26. *Datascope Corp. v. Kontron, Inc.*, 786 F.2d 398, 229 U.S.P.Q. (BNA) 41 (Fed. Cir. 1986), *aff'g* 611 F. Supp. 889 (D. Mass. 1985) (order granting preliminary injunction).
  27. *Atlas Powder v. Ireco Chemicals*, 773 F.2d 1230, 227 U.S.P.Q. (BNA) 289 (Fed. Cir. 1985) (affirming order granting preliminary injunction).
  28. *Roper Corp. v. Litton Systems, Inc.*, 757 F.2d 1266, 225 U.S.P.Q. (BNA) 345 (Fed. Cir. 1985), *aff'g* 589 F. Supp. 823 (N.D. Ill. 1984) (motion for preliminary injunction denied).
  29. *Smith Int'l, Inc. v. Hughes Tool Co.*, 718 F.2d 1573, 219 U.S.P.Q. (BNA) 686 (Fed. Cir. 1983), *cert. denied*, 464 U.S. 996 (1988), *rev'g* 664 F.2d 1373, 215 U.S.P.Q.



(BNA) 592 (9th Cir. 1982) (motion for preliminary injunction denied).

B. DISTRICT COURT CASES, WITH NO REPORTED FEDERAL CIRCUIT OPINION:

1. *The Uppjohn Co. v. Medtron Laboratories, Inc.*, 751 F. Supp. 416 (S.D.N.Y. Oct. 12, 1990) (motion for preliminary injunction granted).
2. *Saes Getters, S.P.A. v. Ergenics, Inc.*, No. 89-649 (D. N.J. July 30, 1990) (unpublished disposition) (motion for preliminary injunction granted with respect to the Boffito patent).
3. *Oscar Mayer Goods Corp. v. Sara Lee Corp.*, 743 F. Supp. 1326 (W.D. Wis. 1990) (motion for preliminary injunction against defendant's second package DESIGN denied).
4. *Con-Vey/Keystone, Inc. v. AM Industries, Inc.*, No. 88-1253-DA (D. Or. June 4, 1990) (unpublished disposition) (review of a grant of a preliminary injunction resulting in the case being remanded).
5. *Saes Getters, S.P.A. v. Ergenics, Inc.*, 15 U.S.P.Q.2d (BNA) 1212 (D. N.J. 1990) (motion for preliminary injunction granted with respect to the Barosi patent).
6. *Oscar Mayer Foods Corp. v. Sara Lee Corp.*, 15 U.S.P.Q.2d (BNA) 1204 (W.D. Wis. 1990) (motion for preliminary injunction on DESIGN PATENT granted).
7. *Joslyn Mfg. Co. v. Amerace Corp.*, No. 89 C 5775 (N.D. Ill. March 15, 1990) (early trial set in lieu of a determination on the preliminary injunction motion).
8. *Ortho Pharmaceutical Corp. v. Smith*, 15 U.S.P.Q.2d (BNA) 1856 (E.D. Pa. 1990) (order granting preliminary injunction).
9. *Ampex Corp. v. Abekas Video Systems, Inc.*, 15 U.S.P.Q.2d (BNA) 1219 (N.D. Cal. 1990) (motion for preliminary injunction denied).
10. *Pharmacia, Inc. v. Frigitronics, Inc.*, No. 84-1923 (D. Mass. Jan. 17, 1990) (order granting preliminary injunction).
11. *Allegheny Ludlum Corp. v. Nippon Steel Corp.*, No. 89-5940 (E.D. Pa. Jan. 5, 1990) (unpublished disposition) (motion for preliminary injunction denied).
12. *Moore Business Forms, Inc. v. Wallace Computer Services, Inc.*, 14 U.S.P.Q.2d (BNA) 1849 (N.D. Ind. 1989) (motion for preliminary injunction granted).

13. *We Care Inc. v. Ultra-Mark Int'l Corp.*, 14 U.S.P.Q.2d (BNA) 1804 (D. Minn. 1989) (motion for preliminary injunction granted).
14. *J-Star Indus., Inc. v. Oakley*, 720 F. Supp. 1291 (W.D. Mich. 1989) (motion for preliminary injunction denied).
15. *Crucible Materials Corp. v. Sumitomo Metals Co.*, 719 F. Supp. 14 (D.D.C. 1989) (motion for preliminary injunction denied).
16. *Amsted Indus., Inc. v. Nat'l Castings, Inc.*, No. 88 C 0924 (N.D. Ill. April 13, 1989) (unpublished disposition) (motion for preliminary injunction denied).
17. *Kalipharma, Inc. v. Bristol-Myers, Co.*, 707 F. Supp. 741 (S.D.N.Y. 1989) (motion for preliminary injunction denied).
18. *Marketing Displays, Inc. v. Pacific Safety Supply, Inc.*, No. 890125 (D. Or. Feb. 17, 1989) (unpublished disposition) (order granting preliminary injunction).
19. *Biocraft Laboratories v. Bristol-Myers Co.*, No. 89-158 (D.N.J. Feb. 24, 1989) (unpublished disposition) (order granting preliminary injunction).
20. *Russell William, Ltd. v. ABC Display and Supply, Inc.*, 11 U.S.P.Q.2d (BNA) 1812 (E.D.N.Y. 1989) (motion for preliminary injunction denied).
21. *Whistler Corp. v. Dynascan Corp.*, 12 U.S.P.Q.2d (BNA) 1647 (N.D. Ill. 1989) (unpublished disposition) (motion for preliminary injunction denied).
22. *Amgen, Inc. v. Chugai Pharmaceutical Co.*, No. 87-2617-Y (D. Mass. Feb. 7, 1989) (order granting preliminary injunction requiring alleged infringer to place profits from sale of patented drug with court).
23. *Automotive Prods. plc v. Federal-Mogul Corp.*, 11 U.S.P.Q.2d (BNA) 1471 (E.D. Mich. 1989) (order granting preliminary injunction).
24. *Archive Corp. v. Cipher Products Inc.*, 12 U.S.P.Q.2d (BNA) 1464 (C.D. Cal. 1988) (motion for preliminary injunction denied).
25. *Sensormatic Electronics Corp. v. Minnesota Mining & Mfg. Co.*, 10 U.S.P.Q.2d (BNA) 1467 (S.D. Fla. 1988) (order granting preliminary injunction).
26. *Zeller Plastik, Koehn, Grabner & Co. v. Joyce Molding Corp.*, 698 F. Supp. 1204 (D. N.J. 1988) (order granting preliminary injunction).
27. *Johnson & Johnson Consumer Prods., Inc. v. Ormco Corp.*, Nos. 87-341, 87-547 (D. Del. Sept. 29, 1988) (un-

- published disposition) (order granting preliminary injunctions for both parties).
28. *Designs for Leisure, Ltd. v. Murrey & Cons Co.*, 9 U.S.P.Q.2d (BNA) 1159 (C.D. Cal. 1988) (order granting preliminary injunction for DESIGN PATENT).
  29. *American Antenna Corp. v. Wilson Antenna, Inc.*, 690 F. Supp. 924 (D. Nev. 1988) (order granting preliminary injunction on DESIGN PATENT).
  30. *Tri-Tech, Inc. v. Engineering Dynamics Corp.*, No. 88-0883-H (D. Mass. June 23, 1988) (unpublished disposition) (order granting preliminary injunction).
  31. *Lubrizol Corp. v. Exxon Corp.*, 7 U.S.P.Q.2d (BNA) 1513 (N.D. Ohio 1988) (order granting preliminary injunction).
  32. *Medtronic, Inc. v. Telectronics, Inc.*, 5 U.S.P.Q.2d (BNA) 649 (D. Colo. 1987) (motion for preliminary injunction denied).
  33. *Toro Co. v. Textron, Inc.*, 5 U.S.P.Q.2d (BNA) 1616 (W.D.N.C. 1987) (order granting preliminary injunction).
  34. *Amicus, Inc. v. Post-Tension of Texas, Inc.*, 686 F. Supp. 583 (S.D. Tex. 1987) (order granting preliminary injunction).
  35. *Turbo Tek Enterprises, Inc. v. F.P. Feature Products, Inc.*, No. 87 C 7438 (N.D. Ill. Oct. 7, 1987) (unpublished disposition) (memorandum opinion granting preliminary injunction).
  36. *Amoco Corp. v. Exxon Chemical Co.*, 7 U.S.P.Q.2d (BNA) 1453 (N.D. Ga. 1987) (motion for preliminary injunction denied).
  37. *John Fluke Mfg. Co. v. North American Soar Corp.*, 5 U.S.P.Q.2d (BNA) 1657 (D. N.J. 1987) (order granting preliminary injunction).
  38. *Pittway Corp. v. Black & Decker, Inc.*, 667 F. Supp. 585, 5 U.S.P.Q.2d (BNA) 1052 (N.D. Ill. 1987) (motion for preliminary injunction denied).
  39. *Scripps Clinic v. Genentech, Inc.*, 3 U.S.P.Q.2d (BNA) 1481 (N.D. Cal. 1987) (motion for preliminary injunction denied).
  40. *MacDonald Assoc. v. Crownmark Corp.*, 2 U.S.P.Q.2d (BNA) 1235 (D.R.I. 1987) (motion for preliminary injunction on DESIGN PATENT denied).
  41. *Glasstech, Inc. v. AB Kyro OY*, 635 F. Supp. 465 (N.D. Ohio 1986) (order granting preliminary injunction).

42. *Rexnord, Inc. v. Laitram Corp.*, 628 F. Supp. 467 (E.D. Wis. 1986) (motion for preliminary injunction denied).
43. *Westhem Corp. v. Poly-Seal Corp.*, 4 U.S.P.Q.2d (BNA) 1534 (D. Md. 1986) (bench ruling granting preliminary injunction on re-issued DESIGN PATENT).
44. *Spalding & Evenflo Co. v. Acushnet Co.*, No. 81-0088-N (D. Mass. Nov. 28, 1986) (order granting preliminary injunction).
45. *Tennant Co. v. Hako Minuteman, Inc.*, 1 U.S.P.Q.2d (BNA) 2042 (N.D. Ill. 1986) (motion for preliminary injunction denied).
46. *Upjohn Co. v. Riahom Corp.*, 641 F. Supp. 1209 (D. Del. 1986) (motion for preliminary injunction denied).
47. *Rexnord, Inc. v. Laitram Corp.*, 1 U.S.P.Q.2d (BNA) 1923 (E.D. Wis. 1986) (order granting preliminary injunction).
48. *Unique Concepts, Inc. v. Manuel*, 231 U.S.P.Q. (BNA) 268 (N.D. Ill. 1986) (motion for preliminary injunction denied).
49. *Augat, Inc. v. John Mezzalingua Assoc., Inc.*, 1 U.S.P.Q.2d (BNA) 1912 (N.D.N.Y. 1986) (order granting preliminary injunction).
50. *Imi-Tech Corp v. Gagliani*, 6 U.S.P.Q.2d (BNA) 1241 (S.D. Cal. 1986) (order granting preliminary injunction).
51. *Whittar Indus., Ltd. v. Superior Indus. Int'l, Inc.*, 230 U.S.P.Q. (BNA) 68 (C.D. Cal. 1986) (order granting preliminary injunction in part on DESIGN PATENT).
52. *Medeco Security Locks Inc. v. Cinquini*, 229 U.S.P.Q. (BNA) 398 (D. Mass. 1985) (order granting preliminary injunction).
53. *Fraige v. Classic Corp.*, 230 U.S.P.Q. (BNA) 223 (C.D. Cal. 1985) (order granting preliminary injunction).
54. *Hopkins Mfg. Corp. v. Revco D.S., Inc.*, No. 85-2586-S (D. Kan. Nov. 27, 1985) (unpublished disposition) (motion for preliminary injunction denied).
55. *SMI Indus. Canada, Ltd. v. Caelter Indus., Inc.*, 586 F. Supp. 808 (N.D.N.Y. 1984) (motion for preliminary injunction on patent infringement denied).
56. *CBS, Inc. v. ENCO Indus., Inc.*, 585 F. Supp. 1291 (S.D.N.Y. 1984) (motion for preliminary injunction denied).
57. *Gravity Guidance, Inc. v. Weseman*, 220 U.S.P.Q. (BNA) 1038 (D. Minn. Oct. 17, 1983) (order granting preliminary injunction).

## APPENDIX 2

## PRELIMINARY INJUNCTIONS IN 29 PATENT CASES THAT CAME BEFORE THE FEDERAL CIRCUIT. THE YEAR REFERENCED IS THAT OF THE FEDERAL CIRCUIT DECISION.

| YEAR          | GRANTED* | PRIOR ADJ. |    | DENIED** | PRIOR ADJ. |    | DENIAL VACATED BY CAFC*** | PRIOR ADJ. |    | GRANT VACATED BY CAFC*** | PRIOR ADJ. |    |
|---------------|----------|------------|----|----------|------------|----|---------------------------|------------|----|--------------------------|------------|----|
|               |          | Yes        | No |          | Yes        | No |                           | Yes        | No |                          | Yes        | No |
| October, 1983 | 1        | 1          | 0  | 0        | 0          | 0  | 0                         | 0          | 0  | 0                        | 0          | 0  |
| 1984          | 0        | 0          | 0  | 0        | 0          | 0  | 0                         | 0          | 0  | 0                        | 0          | 0  |
| 1985          | 1        | 1          | 0  | 1        | 0          | 0  | 0                         | 0          | 0  | 0                        | 0          | 0  |
| 1986          | 1        | 1          | 0  | 0        | 0          | 0  | 0                         | 0          | 0  | 1†                       | 0          | 1† |
| 1987          | 1        | 1          | 0  | 1        | 0          | 1  | 0                         | 0          | 0  | 0                        | 0          | 0  |
| 1988          | 3        | 2          | 1  | 1        | 0          | 1  | 1                         | 1          | 0  | 0                        | 0          | 0  |
| 1989          | 5†       | 0          | 5† | 2        | 0          | 2  | 1                         | 0          | 1  | 2                        | 0          | 2  |
| October, 1990 | 2        | 0          | 2  | 6†       | 0          | 6† | 0                         | 0          | 0  | 0                        | 0          | 0  |
| TOTAL         | 14       | 6          | 8  | 11       | 1          | 10 | 2                         | 0          | 2  | 3                        | 0          | 3  |

\* This term indicates that the patent owner was entitled to a preliminary injunction after the Federal Circuit decision, whether or not there was an affirmation or reversal of a district court's grant or denial of a preliminary injunction.

\*\* This term indicates that the patent owner was not entitled to a preliminary injunction after the Federal Circuit decision, whether or not there was an affirmation or reversal of a district court's grant or denial of a preliminary injunction.

\*\*\* These cases are not included in the figures to the left. This is a breakdown of those cases where the Federal Circuit vacated the lower court's decision.

† One of these cases concerned a design patent.

NB *McAulay v. United States Banknote Corp.*, Nos. 90-1218, 90-1220 (Fed. Cir. Oct. 10, 1990) involved two patents whereby an injunction was granted as to one and not the other. This case is recorded in the above chart as two separate motions.

### APPENDIX 3

PRELIMINARY INJUNCTIONS IN 57 PATENT CASES BEFORE THE FEDERAL DISTRICT COURTS THAT HAVE NOT BEEN APPEALED TO THE FEDERAL CIRCUIT.

| YEAR          | GRANTED* | PRIOR ADJ. |     | DENIED**        | PRIOR ADJ. |                 |
|---------------|----------|------------|-----|-----------------|------------|-----------------|
|               |          | Yes        | No  |                 | Yes        | No              |
| October, 1983 | 1        | 0          | 1   | 0               | 0          | 0               |
| 1984          | 0        | 0          | 0   | 2               | 0          | 2               |
| 1985          | 2        | 0          | 2   | 1               | 0          | 1               |
| 1986          | 7††      | 2          | 5†† | 4               | 1          | 3               |
| 1987          | 5        | 1          | 4   | 4†              | 1†         | 3               |
| 1988          | 7††      | 0          | 7†† | 1               | 1          | 0               |
| 1989          | 4        | 0          | 4   | 6               | 2          | 4               |
| October, 1990 | 8†       | 1          | 7†  | 3 <sup>1Δ</sup> | 0          | 3 <sup>1Δ</sup> |
| TOTAL         | 34       | 4          | 30  | 21              | 5          | 16              |

† One of these cases concerned a design patent.

†† Two of these cases concerned design patents.

Δ This figure does not include Joslyn Mfg. Co. v. Amerace Corp., No. 89 C 5775 (N.D. Ill. March 15, 1990) (where the court decided to try the infringement suit in the immediate future instead of trying the suit twice, once in a preliminary injunction hearing and then at trial). This figure also does not include Con-Vay/Keystone, Inc. v. AM Industries, Inc., No. 88-1253-DA (D. Or. June 4, 1990) (where a review of a grant of a preliminary injunction resulted in the case being remanded).

**APPENDIX 4**

**PRELIMINARY INJUNCTIONS IN THE FEDERAL CIRCUIT AND DISTRICT COURTS. THE YEAR REFERENCED IS THAT OF THE APPELLATE DECISION IF APPEALED.**

| YEAR          | GRANTED*  | PRIOR ADJ. |           | DENIED**  | PRIOR ADJ. |           | DENIAL VACATED BY CAFC*** | PRIOR ADJ. |          | GRANT VACATED BY CAFC*** | PRIOR ADJ. |          |
|---------------|-----------|------------|-----------|-----------|------------|-----------|---------------------------|------------|----------|--------------------------|------------|----------|
|               |           | Yes        | No        |           | Yes        | No        |                           | Yes        | No       |                          | Yes        | No       |
| October, 1983 | 2         | 1          | 1         | 0         | 0          | 0         | 0                         | 0          | 0        | 0                        | 0          | 0        |
| 1984          | 0         | 0          | 0         | 2         | 0          | 2         | 0                         | 0          | 0        | 0                        | 0          | 0        |
| 1985          | 3         | 1          | 2         | 2         | 1          | 1         | 0                         | 0          | 0        | 0                        | 0          | 0        |
| 1986          | 8††       | 3          | 5††       | 4         | 1          | 3         | 0                         | 0          | 1†       | 0                        | 1†         | 0        |
| 1987          | 6         | 2          | 4         | 5†        | 1          | 4         | 0                         | 0          | 0        | 0                        | 0          | 0        |
| 1988          | 10††      | 2          | 8††       | 2         | 1          | 1         | 1                         | 0          | 1        | 0                        | 0          | 0        |
| 1989          | 9†        | 0          | 9†        | 8         | 2          | 6         | 1                         | 0          | 1        | 2                        | 0          | 2        |
| October, 1990 | 10†       | 1          | 9†        | 9††Δ      | 0          | 9††Δ      | 0                         | 0          | 0        | 0                        | 0          | 0        |
| <b>TOTAL</b>  | <b>48</b> | <b>10</b>  | <b>38</b> | <b>32</b> | <b>6</b>   | <b>26</b> | <b>2</b>                  | <b>0</b>   | <b>2</b> | <b>3</b>                 | <b>0</b>   | <b>3</b> |

\* This term indicates that the patent owner was entitled to a preliminary injunction after the Federal Circuit decision, whether or not there was an affirmation or reversal of a district court's grant or denial of a preliminary injunction.  
 \*\* This term indicates that the patent owner was not entitled to a preliminary injunction after the Federal Circuit decision, whether or not there was an affirmation or reversal of a district court's grant or denial of a preliminary injunction.  
 \*\*\* These cases are not included in the figures to the left. This is a breakdown of those cases where the Federal Circuit vacated the lower court's decision.  
 † One of these cases concerned a design patent.  
 †† Two of these cases concerned a design patent.  
 Δ This figure does not include Joslyn Mfg. Co. v. Amerace Corp., No. 89 C 5775 (N.D. Ill. March 15, 1990) (where the court decided to try the infringement suit in the immediate future instead of trying the suit twice; once in a preliminary injunction hearing and then at trial). This figure also does not include Con-Vey/Keystone, Inc. v. AM Industries, Inc., No. 88-1253-DA (D. Or. June 4, 1990) (where a review of a grant of a preliminary injunction resulted in the case being remanded).